



CLASSIC TT & MANX GRAND PRIX

SUPPLEMENTARY REGULATIONS



CONTENTS

	IMPORTANT INFORMATION	Page 2
1	ANNOUNCEMENT	Page 4
2	SECRETARY OF MEETING	Page 4
3	OFFICIALS	Page 4
4	COURSE	Page 5
5	RACE PROGRAMME	Page 5
6	ELIGIBILITY	Page 5
7	ENTRIES PROCEDURE & INSURANCE CONTRIBUTION	Page 7
8	INSURANCE/MACHINES RIDDEN ON PUBLIC HIGHWAY	Page 7
9	SIGNING-ON/BRIEFINGS	Page 8
10	TECHNICAL INSPECTIONS	Page 10
11	FLAG SIGNALS	Page 13
12	PRACTICE	Page 13
13	QUALIFICATION	Page 15
14	RIDING NUMBERS	Page 16
15	RACE PROCEDURE	Page 16
16	PROTESTS AND APPEALS	Page 18
17	WINNERS ENCLOSURE	Page 18
18	GARLANDING CEREMONY	Page 19
19	AWARDS	Page 19
20	TRANSPONDERS & AUTOMATIC TIMING	Page 19
21	ON BOARD CAMERAS & GPS	Page 19
22	MOBILE PHONES	Page 19
23	PADDOCK	Page 20
24	PERSONNEL PASSES	Page 23
25	VEHICLE RECOVERY SERVICE	Page 25
26	ACCEPTANCE OF RECORDS	Page 25
27	BREACH OF REGULATIONS	Page 25
28	INDEMNIFICATION OF CLUB	Page 26
29	JURISDICTION	Page 26
30	PUBLICITY	Page 26
31	MERCHANDISING	Page 26
32	MISCELLANEOUS	Page 26
33	USEFUL CONTACTS	Page 27
	APPENDIX A - Technical requirements for all race machines	Page 28
	APPENDIX B – Regulations specific to MGP race machines	Page 30
	APPENDIX C- Regulations specific to Classic TT race machines	Page 33
	SUMMARY OF TIMES	Page 37

Important Information

REGULATIONS

Please note that these regulations are heavily revised for 2014 and all competitors, teams and entrants are encouraged to read them thoroughly before entering the 2014 Manx Grand Prix Races and/or Classic TT Races.

CLOSING DATE FOR ENTRIES

Entries for the Classic TT Races close on **Monday 31 March 2014**.

Entries for Manx Grand Prix Races close on **Saturday 7 June 2014**.

LICENCE REQUIREMENTS

ACU and SACU licence holders must have held as a minimum a National Licence issued by the ACU or SACU for at least six months prior to the first day of practising. Competitors from other FMN's must have held an FIM International Non - Championship Licence for a minimum of six months prior to the first day of practising.

In addition to enter this event all competitors must hold a "TT Course Licence" issued by the ACU at a cost of £25.00 in addition to any normal licence fees. An application form for such a licence may be downloaded from www.manxgrandprix.org and should be returned to the Auto Cycle Union.

Please note - A "TT Course Licence" issued by the ACU does not guarantee an entry into the Manx Grand Prix or Classic TT Races.

Competition licences, starting permission (for non ACU/SACU licence holders) and TT Course licences must be produced when signing on.

COMMENCEMENT OF PRACTICE

Riders with previous experience on the TT Course may apply for dispensation to the Clerk of the Course to commence practice no later than Wednesday 20 August. All newcomer riders must have commenced practice on Saturday 16 August and completed 3 laps before Wednesday 20 August.

PERSONNEL PASSES

A number of significant revisions to the access granted by personnel passes in restricted areas in around the paddock and start line area and all competitors, teams and entrants are encouraged to make themselves familiar with these changes before the 2014 Manx Grand Prix Races and Classic TT.

NUMBER BOARDS

Riders may use their own painted number boards but if they do so they must be matt and the RAL colours specified. Please note that some class number board colours have been changed for 2014. For more information see regulation 10.



Important Information

RIDING RACING MOTORCYCLES ON THE PUBLIC HIGHWAY

No motorcycle may be ridden on open roads, not even to and from the starting point at any time, without Road Traffic Act Insurance. This cover may be obtained from the Race Office. Riders may wish to explore the possibilities of arranging cover through their own insurers for this purpose.

Third party insurance for all riders and personal accident insurance for ACU and SACU licence holders during the races and official practices are included in the Insurance Contribution. Non ACU and SACU licence holders must have Personal Accident insurance as required by their own national federation (see Reg. 8).

Insurance for increased benefits can be effected by application direct to:-

Dawn Luby

Lockton International
6th Floor
19 Spring Gardens
Manchester
M2 1FB

Tel: +44(0)161 828 3326
Mobile: +44(0)7775574863
Email: dawn.luby@uk.lockton.com

This insurance can also be obtained during signing on periods.

CONTACTS

MMCC Office

The Grandstand,
Glencrutchery Road,
Douglas,
Isle of Man,
IM2 6DA

Telephone : (01624) 644649
Fax : (01624) 620174
Email: mgp@manx.net
www.manxgrandprix.org

Motorsport Team

Department of Economic Development
St Georges Court
Upper Church Street
Douglas
Isle of Man
IMI IES

Telephone +44 (0)(1624) 686815
Email: info@iomtt.com
www.iomtt.com



2014 Manx Grand Prix Races and Classic TT Races Supplementary Regulations

I. ANNOUNCEMENT

Manx Motor Cycle Club Limited, "MMCC" (a company incorporated in the Isle of Man (no 007491C)) whose registered office is situated at The Grandstand, Glencrutchery Road, Douglas, Isle of Man, IM2 6AD, ("the Club") will organise the Manx Grand Prix and Classic TT Races over the TT Mountain Course in the Isle of Man from 23 to 29 August. Official Practice will be from 16 to 22 August with additional practice on 23, 25 and 27 August. Permit No ACU 40751, FIM Inscription No IMN 191/49 and Temporary Course Certificate No TT001.

The MMCC is the owner of the logos, associated trademarks and designs of the Manx Grand Prix races and has agreed to grant to Department of Economic Development (DED) the use of same for the term of the existing contract between the parties. The DED (an Isle of Man Government Department), whose registered office is St Georges Court, Upper Church Street, Isle of Man, IM1 1EX, is the owner of the intellectual property rights logos, associated trademarks and designs of the Isle of Man TT Races, Classic TT Races and Isle of Man Festival of Motorcycling.

The status of the Meeting is an International. The Meeting will be held under the National Sporting Code and Standing Regulations for Road Racing of the ACU, these supplementary regulations and any further instructions issued or official announcements made ("The Regulations"). The Club may publish supplementary instructions on the official notice board in the Race Office at the rear of the Grandstand. Riders will be deemed to have received due notice of any instruction so published.

The regulations will not be altered, except as provided for in the National Sporting Code and may be interpreted only by the Stewards of the Meeting. Their decisions will be final except as provided in the National Sporting Code.

2. SECRETARY OF THE MEETING

Caroline Etherington,
MMCC Office,
The Grandstand,
Glencrutchery Road,
Douglas,
Isle of Man,
IM2 6DA.

Telephone : (01624) 644649
E-mail: mgp@manx.net

3. OFFICIALS

ACU Steward:	TBA
ACU Centre Steward:	TBA
Club Steward	TBA
Classic TT Eligibility Officer	Mark George
Clerk of the Course:	Philip Taubman ACU 29276
Deputy Clerks of the Course/Operations:	Ruth Costain, Lizzie Kinvig
Deputy Clerk of the Course/Start/Finish:	Peter Cain
Chief Incident Officer:	Ned Bowers
Medical Director:	Dr David Stevens MBE
Senior Medical Officers Panel:	Dr Gareth Davies, Dr Gruff Evans, Dr Heike Romer
Chief Timekeeper:	Kevin Brookes
Chief Technical Officer:	Peter Maddocks
Deputy Chief Technical Officers:	Jeff Kirby, Joanne Rowe, Trevor Denning
Engine Measurer:	Keith Spencer, Joanne Rowe, Trevor Denning
MGP Riders Liaison Officers:	Carolynn Sells, John McBride
Classic TT Rider Liaison Officers:	John Barton, Richard Quayle

4. COURSE

The Meeting will be held on the 'Mountain' circuit which is 60.70km (37.73 miles) in length, on highway which is closed to the public during practice and race periods.

5. PROGRAMME OF RACES

Saturday 23 August – Classic TT Race Day

13:00 hrs	Race CTT1	The 500cc Classic TT Race	(4 laps)
-----------	-----------	---------------------------	----------

Monday 25 August – Classic TT and Manx Grand Prix Race Day

10:15 hrs	Race CTT2	The 350cc Classic TT Race	(4 laps)
-----------	-----------	---------------------------	----------

13:30 hrs	Race CTT3	The Formula 1 Classic TT Race	(4 laps)
-----------	-----------	-------------------------------	----------

13:30 hrs	Race CTT4	The Formula 2 Classic TT Race	(4 laps)
-----------	-----------	-------------------------------	----------

(Races 3 & 4 will run concurrently)

15:45 hrs	Race MGP1	The Newcomers Race A	(4 laps)
-----------	-----------	----------------------	----------

15:45 hrs	Race MGP2	The Newcomers Race B	(4 laps)
-----------	-----------	----------------------	----------

15:45 hrs	Race MGP3	The Newcomers Race C	(4 laps)
-----------	-----------	----------------------	----------

(Races 1, 2 and 3 will run concurrently)

Wednesday 27 August – Manx Grand Prix Race Day

10:15 hrs	Race MGP4	The Junior Manx Grand Prix Race	(4 laps)
-----------	-----------	---------------------------------	----------

13:15 hrs	Race MGP5	The SuperTwin Manx Grand Prix Race	(4 laps)
-----------	-----------	------------------------------------	----------

13:15 hrs	Race MGP6	The Lightweight Manx Grand Prix Race	(4 laps)
-----------	-----------	--------------------------------------	----------

(Races 5 and 6 will run concurrently)

Friday 29 August – Manx Grand Prix Race Day

11:30 hrs	Race MGP7	The Senior Manx Grand Prix Race	(4 laps)
-----------	-----------	---------------------------------	----------

6. ELIGIBILITY

(a) Riders

ACU and SACU licence holders must have held as a minimum a National Licence issued by the ACU or the SACU for at least six months prior to the first day of practising. Competitors from other FMN's must have held an FIM International Non - Championship Licence for a minimum of six months prior to the first day of practising. In addition to enter this event all competitors must hold a "TT Mountain Course Licence" issued by the ACU at a cost of £25.00 in addition to any normal licence fees. An application form for such a licence may be downloaded from www.manxgrandprix.org and should be returned to the ACU.

In these regulations and in any other instructions or directive issued by the Club, the term "rider" shall refer to any person who has been accepted as a rider in any of the races.

Riders must be 18 years or older on 16 August 2014.

(b) Additional conditions for classes

Newcomers

The only riders regarded as newcomers are those who have not previously taken part in any motorcycle race run over the TT Mountain Course. A rider who has previously competed on the TT Mountain Course only as a TT sidecar driver or passenger will be regarded as a Newcomer. Riders entering the Newcomers Race may also enter for the Lightweight, SuperTwin, Junior or Senior Manx Grand Prix Races but may compete in these races only if they have started in the Newcomers Race and achieved the qualifying time for the other races entered. A Newcomer taking part in the Classic TT Race immediately prior to the Manx Grand Prix is not eligible to enter the Newcomers Race, ie competitors may not enter both Classic TT and Newcomers A/B/C.

All Newcomers (modern and classic) must practice with the ClassicTT classes for the first 2 practice sessions and may only compete in one race per day.

SuperTwin, Lightweight, Junior & Senior Manx Grand Prix

See Appendix B

Classic TT Races

See Appendix C

(c) Change of Rider

Only with the permission of the Clerk of the Course may a change of rider be allowed. Such permission will be granted only in exceptional cases and after investigation. A substitute rider may be nominated only by a licensed entrant. A change of both rider and make of motorcycle may be permitted at the discretion of the Clerk of the Course.

(d) Medical Examinations

The Club may require any rider at his/her expense to undergo a medical examination by a doctor or by the medical board appointed by the Club and may disqualify a rider on medical advice. Every rider agrees to the results of any such medical examination being given to the Club.

A rider involved in an accident will not be allowed to continue practising or racing until he/she has been passed medically fit by one of the event Medical Officers.

(e) Entrants

Entrants must be in possession of a valid National Entrants or FIM Sponsors Licence for Road Racing.

(f) Machines

- All machines see Appendix A
- MGP Races see Appendix B
- Classic TT Races see Appendix C

7. ENTRY PROCEDURE & INSURANCE CONTRIBUTION

- MGP Races see Appendix B
- Classic TT Races see Appendix C

8. INSURANCE/MACHINES RIDDEN ON PUBLIC HIGHWAY

(a) Insurance

The Organisers undertake to insure each rider; indemnifying him/her against any third party claims made arising out of the races or official practice, excluding claims by other riders, entrants, sponsors or mechanics.

Competitors who hold licences issued by the ACU or the SACU will be covered by Personal Accident insurance during official practice and racing, for the benefits detailed below. The cost of this Personal Accident insurance is included in the insurance contribution. Competitors holding licences issued by a FMN other than the ACU or SACU must submit a Starting Permission countersigned and stamped by the FMN which issued their licence.

This must confirm that, during the meeting and the official practice, they are insured against the risk of personal accident in accordance with the FIM Sporting Code but with additional cover for Medical Treatment and Repatriation costs, as follows:-

- 25,000 Euros - Death
- 50,000 Euros - Temporary Partial Disablement
- 185,000 Euros - Medical Treatment
- 75,000 Euros - Repatriation costs

Alternatively this cover may be purchased from the event Insurance Brokers in the Race Office at the Grandstand during signing on periods at the following rates:-

- MCUI - £85
- Other European Federations - £115
- Rest of the World - £165

For ACU and SACU licence holders, the organisers will arrange personal accident cover for the following benefits:

- £10,000 GBP Death or permanent total disablement
- £20,000 GBP Loss of, or loss of the use of, one or more limbs or eyes
- Competitors resident outside the United Kingdom should ensure they have sufficient private medical insurance to assist them on their return to their place of domicile for any on-going medical expenses incurred from injuries sustained whilst competing in the MGP Races.

Increased insurance benefits can be arranged either in the Race Office at the Grandstand (during the MGP fortnight) or by application to:

Dawn Luby, Lockton International, 6th Floor, 19 Spring Gardens, Manchester, M2 1FB.
Tel: +44(0)161 828 3326, Mobile: +44(0)7775574863, Email: dawn.luby@uk.lockton.com

During the whole of the time the competing motorcycles are in the custody of the Club the motorcycles will be insured by the Club against damage by fire up to a maximum value of £25,000 per machine.

(b) Machines on the Public Highway

- The law of the Isle of Man provides that racing machines shall not be ridden on the public highway, except being used on a journey:-
 - (i) between the place where it is kept and the start of the Course
 - (ii) between the place where it is kept and a point on the Course
 - (iii) from a point on the Course to the place where it is kept; or
 - (iv) between points on the Course

The above is applicable for a period of 3 hours before and 2 hours after a closure period provided that the motorcycle in question is competing in a practice or race during the closure period. During these times, third party insurance must be effective, for the person riding the machine. Any rider reported as having driven his/her motorcycle in such a manner as to constitute a nuisance to the public or in contravention of any law or statutory regulation may be disqualified or otherwise penalised. Third party insurance cover can be obtained from the Race Office. Machines used on the public roads outside these times must comply in every respect with Manx road traffic laws and race numbers **must not** be displayed.

9. SIGNING-ON/BRIEFING

(a) Signing-on

All riders must sign-on at the Press Office, The Grandstand between the following times:

FRIDAY 15 AUGUST	15:00 – 19:00 hrs (All riders including Newcomers)
SATURDAY 16 AUGUST	09:00 – 09:30 hrs (Newcomers only)
	09:30 – 11:30 hrs (All other riders)

- Competition licences, starting permission (for non ACU/SACU licence holders) and TT Course licences detailed in Reg 6 (a)(1), plus leathers, helmets (with visor), boots, gloves, transponders and identification disc MUST be produced personally for examination.
- Local addresses and telephone numbers must be supplied. Any notices posted in the Race Office or sent by the Club to riders at such addresses shall be deemed to have been served.
- All Race Office opening times will be displayed outside the Race Office.
- A declaration must be signed by riders, confirming that they have not sustained any injury or consulted with a doctor regarding any injury or illness since the issue of their licences.
- Each Newcomer will be required to wear a red waistcoat at all times during practice sessions. Waistcoats will be supplied by the Club during signing-on sessions. Replacements can be purchased at a cost of £10 each.

(b) Riders Briefings

- All riders must attend a briefing prior to being permitted to commence practice. The briefings will take place in the Conference Suite adjacent to the Race Office at the following times:

FRIDAY 15 AUGUST	16:00 hrs / 17:00 hrs / 18:00 hrs (Newcomers Only) / 19:30 hrs
SATURDAY 16 AUGUST	10:00 hrs (Newcomers only) / 11:00 hrs & 12:00 hrs (All other riders)
MONDAY 18 AUGUST	16:00 hrs

- All Newcomers must arrive, sign on and attend a Newcomers briefing at 18:00 hrs on Friday 15 August or 10:00 hrs on Saturday 16 August or they may be disqualified.

(c) Technical Briefings

- A technical briefing for competitors and one mechanic per competitor will be held on Saturday 16 August in the Conference Suite adjacent to the Race Office at the following times:-

MGP riders at 13:15 hrs
Classic TT riders at 14:00 hrs & 14:45 hrs

- It is important that each rider is represented at this briefing.

(d) Newcomers' Pit Lane Briefing

- Pit lane briefings will be held for Classic TT and MGP Newcomers on Thursday 21 August at 11:00hrs in the Pit Lane area if dry and Technical Inspections Bay if wet. This briefing is compulsory.

(e) MGP Newcomers' Post Race Briefing

- A post race briefing race will be held on Tuesday 26 August at 11:00hrs for MGP Newcomers A/B/C in the Conference Suite prior to Newcomer riders second race. This briefing is compulsory.

10. TECHNICAL INSPECTIONS

(a) Number plates

Self adhesive numbers and backgrounds must be supplied by the riders. Numbers must be legible and any numbers not meeting with the approval of the Chief Technical Official must be replaced. However riders may use painted backgrounds but if they do so they **must** be matt and the following colours must be used following the RAL colour table:-

Black	9005	Red	3020
Blue	5010	White	9010
Yellow	1003	Green	6002

Three numbers, placed and fixed as directed by the Club shall be displayed on the motorcycle during practice periods and races so as to be clearly visible to marshals from the front and both sides of the machine.

The colours for practice and race number plates will be as follows:

500cc Classic TT	Yellow plates with Black digits	MGP Newcomers (A/B/C)	Red plates with White digits
350cc Classic TT	Blue plates with White digits	Junior MGP	Black plates with White digits
Formula 1 & Formula 2 Classic TT	White plates with Black digits	Lightweight and SuperTwin MGP	Green plates with White digits
		Senior MGP	Yellow plates with Black digits

Please also note: The practice plate colour will be the same as that used for the first race for that motorcycle, i.e. a 600cc machine entered in the Junior MGP (white on black) and Senior MGP (black on yellow) will practice on black plates.

(b) Pre-Practice Technical Inspections

All machines bearing the correct number plates must pass through the Technical Inspections Bay for inspection/approval prior to practice, during the times listed. It is the responsibility of all riders to ensure that all of their clothing (leathers, boots, gloves), helmets and identification discs are in a sound condition and fit for practice and racing. Random checks will be carried in parc ferme and on the start line and anyone failing the inspection will not be permitted to commence practice or race. If a rider is involved in any incident he/she must have their motorcycle, clothing and helmet re-inspected in the Technical Inspection Bay. Riders shall remove fairings from their machines if required by the Chief Technical Officer.

Saturday 16 August	15:00 - 15:45 15:45 - 18:30 17:15 - 19:45	Newcomers incl Classic TT Newcomers Senior, Junior, SuperTwin (No Newcomers) Classic TT, Lightweight
Monday 18 August	16:00 - 18:45 17:15 - 19:45	Senior, Junior, SuperTwin (No Newcomers) Classic TT, Lightweight, All Newcomers
Tuesday 19 August	16:00 - 18:45 17:15 - 19:45	Classic TT, Lightweight, Newcomers B/C Senior, Junior, SuperTwin, Newcomers A
Wednesday 20 August	16:00 - 18:45 17:15 - 19:45	Senior, Junior, SuperTwin, Newcomers A Classic TT, Lightweight, Newcomers B/C
Thursday 21 August	16:00 - 18:45 17:15 - 19:45	Classic TT, Lightweight, Newcomers B/C Senior, Junior, SuperTwin, Newcomers A
Friday 22 August	16:00 - 18:45 17:15 - 19:45	Classic TT, Lightweight, Newcomers B/C Senior, Junior, SuperTwin, Newcomers A
Saturday 23 August	08:00 - 09:30 12:30 - 14:15 14:15 - 15:00	350 Classic TT, F1 & F2 Classic TT Newcomer A, Senior, Junior, SuperTwin, Newcomer B/C, Lightweight
Monday 25 August	15:00 - 16:45	Senior, Junior, SuperTwin, Lightweight
Wed 27 August	12:30 - 14:00	Senior

(c) Pre-Race Technical Inspections

Motorcycles must be presented for pre race Technical Inspections ready to race at the Technical Inspections Bay on each race day at the following times, which must be strictly adhered to.

Saturday 23 August

500cc Classic TT

Nos 61 - 90	10:30 - 11:00 hrs
Nos 31 - 60	11:00 - 11:30 hrs
Nos 1 - 30	11:30 - 12:00 hrs

Monday 25 August

350cc Classic TT

Nos 61 - 90	08:00 - 08:30 hrs
Nos 31 - 60	08:30 - 09:00 hrs
Nos 1 - 30	09:00 - 09:30 hrs

Formula 1 & 2 Classic TT

Nos 61 - 90	10:00 - 10:30 hrs
Nos 31 - 60	10:30 - 11:00 hrs
Nos 1 - 30	11:00 - 11:30 hrs

Newcomers MGP

Nos 61 - 90	13:00 - 13:30 hrs
Nos 31 - 60	13:30 - 14:00 hrs
Nos 1 - 30	14:00 - 14:30 hrs

Wednesday 27 August

Junior MGP

Nos 61 - 90	08:00 - 08:30 hrs
Nos 31 - 60	08:30 - 09:00 hrs
Nos 1 - 30	09:00 - 09:30 hrs

SuperTwin/Lightweight MGP

Nos 61 - 90	10:00 - 10:30 hrs
Nos 31 - 60	10:30 - 11:00 hrs
Nos 1 - 30	11:00 - 11:30 hrs

Friday 29 August

Senior MGP

Nos 61 - 90	09:00 - 09:30 hrs
Nos 31 - 60	09:30 - 10:00 hrs
Nos 1 - 30	10:00 - 10:30 hrs

(c) Pre-Race Technical Inspections (continued)

- NB Riders need not necessarily present their motorcycles personally; Riders shall remove fairings from their machines if required by the Chief Technical Officer.
 - Only the Chief Technical Officer or his Deputy may exceptionally grant an extension to ensure that a machine is properly prepared.
 - Motorcycles must, therefore, be presented for all Technical Inspections, with stands, ready in all respects, for the start of the race, including fuel. The motorcycles will remain in the custody of the Club, after presentation, until 45 minutes before the start.
 - For machine security only two persons, one with the machine and one with the stand, will be permitted into the parc ferme. They shall leave the holding area immediately after their motorcycles have been placed there after Technical Inspections and should note that except by leave of the Chief Technical Officer they cannot have access to their machines until 45 minutes before the start.
-

(d) Post Race Examination

- Every competing motorcycle must be placed in the finishing enclosure where it will be held for as long as may be required. Motorcycles must be collected immediately following an official announcement that they have been released, after which the Club disclaims any responsibility for motorcycles not collected. No responsibility is accepted for equipment at any time.
 - Motorcycles may be examined at the end of the race by the Chief Technical Officer and may be sealed by the Chief Technical Officer for later examination. Every rider shall dismantle, or cause to be dismantled at his/her own expense such parts of his motorcycle as the Clerk of the Course may require for the purposes of such examination, at such time and place as the Chief Technical Officer shall require.
 - No rider shall be deemed to have finished a race or to have set up or broken a lap record or to have accomplished the fastest lap in a race until his/her motorcycle has been examined if so required, and passed.
-

(e) Re-examination

- Motorcycles and protective equipment (helmets, visors, leathers, boots, gloves, identification discs) must be produced personally by each rider for re-examination if a rider falls off his/her machine or at any time if required by the Chief Technical Officer.
-

(f) Change of Motorcycle

- An entrant wishing to change the make or type of motorcycle, after entries have closed, must apply to the Race Office for approval by the Clerk of the Course. The rider must comply with the requirements of Regulation 13 Qualification and must complete 2 practice laps on the machine to be raced.
 - No change of class will be permitted after Tuesday 19 August.
 - NOTE: For the purpose of these regulations, make of machine will be determined by the make of the engine and the make of the engine must be declared at the time of registration.
-

(g) Fuel

Fuel for all practices and races must be one of the following and comply with the general specifications listed in Table 1. Furthermore, only the specified fuel type is permitted for use in classes or engine types as given in Table 2.

Table 1. Fuel type general specifications:

Property	Max Lead Mg/l	MAX RON	MAX MON	Oxygen% m/m	Benzene% v/v
Unleaded petrol	5	102	90	2.7	1.0
Leaded petrol	150	102	90	2.7	1.0
Avgas 100 LL	560	-	102	2.7	5.0

Values in this table are taken from the FIM/ACU regulations and are applied to the fuel types as indicated. For a full specification refer to the FIM regulations for fuel. Alternatives to Avgas 100LL are NOT permitted.

Table 2. Motorcycle classes and engine types with permitted fuel for use:

	250/350/500 Classic TT & Formula Classic TT	Any other 2 stroke	Up to 1000cc 4 strokes Inc. F1 & F2 Classic TT
Unleaded petrol	YES	YES	YES
Leaded petrol	YES	YES	NO
Avgas 100LL	YES	YES	NO

- Where a competitor is using other than Isle of Man sourced pump fuel he/she MUST provide a specification sheet for that fuel when requested by the Chief Technical Officer.
- These regulations strictly prohibit the use of 'Bluegas', power boosters, octane boosters and the like. No additions are allowed to the fuel with the exception of water or standard lubricants sold to the public. The responsibility for providing fuel for practice and races will be the competitor's. It is also the competitor's responsibility to ensure that his allocated filler, which will be provided, operates correctly. Any fuel left in fillers will be drained and removed, however it is the competitor's responsibility to check that his filler has been drained prior to adding his own fuel. The use of other quick filling equipment will not be allowed.
- The Steam Packet Company has stated that fuel may only be carried in the tanks of machines, cans/barrels will not be allowed. Spot checks will be carried out and anyone found in contravention of this ruling will not be permitted passage to the Island.
- In the practice or races, no fuel shall be carried on the motorcycle other than in the tank securely fitted to the motorcycle for the purpose.
- The Club reserves the right at any time before, during or immediately after practising or racing to take samples of the fuels used.
- During practice periods riders can only refuel in the holding area to the north side of the Technical Inspection Bays, engines must be stopped.
- Competitors must supply information at signing on regarding the quantity and location of fuel stored outside the Grandstand. This information will be supplied to the Isle of Man Fire Service.

(h) Fuel Tanks/Capacities

- In the interest of safety, the use of ready fuelled replacement tanks in the pit WILL NOT be permitted.
- Replacement tanks are permitted but must be empty and may only be filled when securely attached to the machine.
- Refuelling during the progress of any race must be carried out at the competitor's designated pit. It is forbidden to open tank filler caps until the machine is stationary at its allotted pit and the engine is switched off. Penalty will be disqualification.

11. FLAG SIGNALS

The following flag signals may be used during practice or a race, and must be immediately obeyed:

NATIONAL FLAG	Start
RED (waved)	Immediate stop, all riders. Pull in where safe. Await marshals' directions.
BLACK WITH ORANGE DISC	Displayed with rider's number - that rider to stop due to mechanical problems.
YELLOW (motionless)	Danger ahead, slow down, no overtaking.
YELLOW (waved)	Danger more imminent, slow down and be prepared to stop, no overtaking.
CHEQUERED	Individual finish

The following advisory flag signals may be displayed:

WHITE WITH BLACK "V"	Bad visibility warning.
WHITE WITH BLACK "SUN" or "S"	Sun dazzle.
YELLOW AND RED STRIPED	Oil, water or other substance is affecting this section of the Course.
WHITE FLAG WITH RED DIAGONAL CROSS	Wet or damp patches are affecting adhesion of a particular section of the Course.
GREEN	Course clear.

12. PRACTICE

(a) General

- Practice on the Course, which will be closed to the public, will be regulated and supervised by the Club and will be allowed ONLY from the 16 August at the times specified. The practice schedule may be altered by the Clerk of the Course due to circumstances or force majeure.
 - During any practice period, the Clerk of the Course or his deputy may decide to flag off riders between Governor's Bridge and the finishing line, in which case the foreshortened lap and the time recorded at the flagging off point will be counted towards qualification for the races.
 - The end of each practice session will be notified by the showing of yellow, chequered and red flags, as detailed at the riders briefing.
 - All riders will slow down and leave the course as directed, where a red flag is shown.
-
-

(b) Practice Periods

Saturday 16 August	17:20 - 17:45	Newcomers inc Classic TT (speed controlled) (untimed)
	17:45 - 18:55	Senior; Junior; SuperTwin (No Newcomers) (untimed)
	19:00 - 20:00	Classic TT, Lightweight, All Newcomers (untimed)
.....		
Monday 18 August	18:20 - 19:00	Senior; Junior; SuperTwin (No Newcomers)
	19:05 - 20:00	Classic TT, Lightweight, All Newcomers
.....		
Tuesday 19 August	18:20 - 19:00	Classic TT, Lightweight, Newcomers B/C
	19:05 - 20:00	Senior; Junior; SuperTwin, Newcomers A
.....		
Wednesday 20 August	18:20 - 19:00	Senior; Junior; SuperTwin, Newcomers A
	19:05 - 20:00	Classic TT, Lightweight, Newcomers B/C
.....		
Thursday 21 August	18:20 - 19:00	Classic TT, Lightweight, Newcomers B/C
	19:05 - 20:00	Senior; Junior; SuperTwin, Newcomers A
.....		
Friday 22 August	18:20 - 19:00	Classic TT, Lightweight, Newcomers B/C
	19:05 - 20:00	Senior; Junior; SuperTwin, Newcomers A
.....		
Saturday 23 August*	09:50 - 10:20	350 Classic TT, F1 & F2 Classic TT
	15:30 - 16:10	Newcomer A, Senior; Junior; SuperTwin
	16:15 - 16:30	Newcomers B/C & Lightweight
.....		
Monday 25 August*	17:45 - 18:10	Senior; Junior; SuperTwin, Lightweight
.....		
Wednesday 27 August*	15:15 - 15:25	Senior
.....		

**subject to race delays*

The above times are subject to alteration due to circumstances or force majeure.

PLEASE NOTE:

- Motorcycles raced in the Junior MGP Race may not be used in the Wednesday 27 August practice session.
- Applications to practice out of session will not be considered unless in exceptional circumstances.

13. QUALIFICATION

- To start a race, a newcomer to the TT Course, qualifying for the first time must complete a total of at least 6 laps, including a speed-controlled lap. Newcomers in any class must have signed on, attended the Newcomers briefing and the Course Instruction on Saturday 16 August and commenced practice, including completion of a speed controlled lap and must have completed 3 laps on or before Wednesday 20 August, or they may be disqualified.
- Riders who have qualified to start in any previous race on the Mountain Circuit (TT or MGP) shall be required to have signed on and commenced practice on or before Wednesday 20 August to complete a total of at least 5 laps.
- A minimum of 2 laps (3 laps in the case of newcomers) must be completed on each machine entered, one of which must be within the qualifying time.
- In every case all qualifying laps must be completed on the motorcycle to be ridden in the race or on a machine of the class.

QUALIFICATION TIMES:

- Please note: Saturday 23 August practice period for all classes except the 500cc Classic TT will be timed and can be counted towards qualification.

Manx Grand Prix

Senior	23m 00s (98.42 mph)
Junior	23m 00s (98.42 mph)
SuperTwin	24m 30s (92.40 mph)
Lightweight	25m 30s (88.77 mph)
Newcomer A	24m 30s (92.40 mph)
Newcomer B	26m 30s (85.42 mph)
Newcomer C	28m 30s (79.43 mph)

Classic TT

500cc Classic TT

500 GP1	26m 14s (86.30 mph)
500 GP2	25m 21s (89.30 mph)
500 P1	28m 18s (80.00 mph)
500 P2	29m 00s (78.00 mph)

350cc Classic TT

350 GP1	28m 40s (79.00 mph)
350 GP2	27m 57s (81.00 mph)
350 P1	29m 24s (77.00 mph)
350 P2	30m 11s (75.00 mph)
250	29m 40s (76.30 mph)

Formula 1 Classic TT

F1 GP1	24m 36s (92.00 mph)
F1 GP2	23m 02s (98.30 mph)
F1 P1	25m 09s (90.00 mph)
F1 P2	26m 00s (87.00 mph)
FC	26m 19s (86.00 mph)

Formula 2 Classic TT

F2 GP2	25m 26s (89.00 mph)
F2 P1	27m 30s (82.30 mph)
F2 P2	26m 14s (86.30 mph)
F2 P3	30m 04s (75.30 mph)
F2 P4	26m 38s (85.00 mph)

- A list of non-qualifiers will be posted in the Race Office at 09:30 hrs on Sunday 24 August at 09:30 hrs.
- All qualifying, including that on race days will be officially timed and count towards qualification. Qualifying must be at the sole discretion of the Clerk of the Course and there will be no right of Protest or Appeal.

14. RIDING NUMBERS

No applications for a change of number will be accepted. All competitors will be issued a riding number which will be listed in the official race guide and displayed on machines in the usual manner. Numbers in each class will be allocated by the organisers and competitors will start races in numerical order at 10 second intervals up to a maximum of 90 starters. The Clerk of the Course does reserve the right to make a change of number when circumstances dictate that it is desirable to do so.

15. RACE PROCEDURE

In exceptional circumstances, the start of any race may be officially delayed or a race may be reduced in number of laps or, if necessary, postponed until the following day or another designated day, abandoned or cancelled. Riders will be started at intervals of 10 seconds singly in each race or at such other intervals as the Club may determine.

(a) Start Preliminaries

First Signal - 45 minutes before start.

Competitors take possession of machines in assembly area. Engines may be started for warm up period. Petrol tanks and oil may be topped up and adjustments made.

Second Signal - 30 minutes before start.

Third Signal - 15 minutes before start

Competitors marshalled to starting grid and lined up in order. Riders on the grid may at this stage make adjustments to the motorcycle or change tyres to suit the course conditions. Tyre warmers may be used on the grid, powered by a generator. Only one generator per machine may be used. The generator must be of the "hand carried" type and have a maximum output capacity of one kilowatt. The noise limit of the generator is 65 dB/A. No batteries or other electrical supplies are permitted on the grid except a self-contained starting device may be used. All adjustments and changes of tyres/wheels must be completed by the fourth signal.

Fourth Signal - 5 minutes before start.

Stand to, clear grid on the instructions of officials. Engines must be running. Exit gate from warm-up/assembly area to start line will close.

- **Riders will not start until the starting flag is dropped.** Clutch or push starts will be permitted in all races.
- Any rider who starts before the starting flag is dropped, or who fails to start immediately the starting flag is dropped may be penalised.
- A rider who is not in position to start within 10 seconds of the scheduled starting time may only start 10 seconds after the last competitor is scheduled to start. The Clerk of the Course may adjust the starting time to coincide with the new starting position.
- Only during the start procedure is a competitor permitted to stop on the course adjacent to his pit. At all other times a rider must use the pit access road and stop in front of his designated pit.

(b) Pit Area and Pit Stops

(1) Pit Area

The Pit Area is a Licensed Petroleum Storage Area under the Isle of Man Dangerous Goods Act and as such the following conditions apply:-

- There must be NO SMOKING or naked lights. Engines must be stopped whilst being refuelled. Any electrical equipment used or taken within 14ft of refuelling equipment must be either intrinsically safe or flame-proofed. This includes two-way radios, transistor radios, cellular telephones, cameras using electronic flash or motor drive and power tools. Spare batteries must be protected to prevent shorting across the terminals. Manx Radio earpieces are permitted. Please note that simply wrapping electrical equipment does not make it intrinsically safe and therefore no such equipment including electrically powered tools will be permitted in the pit area.
- Petrol cans used for filling and draining must be metal or BSI approved. Spare tanks in pits must be empty.
- Filling or refuelling of quick-fillers can be done only once the roads have closed and after the fire service have arrived. Fire retardant overalls must be worn when filling or refueling tanks.
- When quick-fillers are being filled or drained, only those persons immediately involved and race officials are permitted in the pit area.
- Quick-fillers must be drained when the pit lane is closed towards the end of the race. Any fuel not removed will become the property of the Club. Fire retardant overalls must be worn when draining fuel tanks.
- Unused fuel or empty drums which have contained fuel must not be carried beneath the Grandstand but may be taken across the pit lane only at the start line end.

(2) *Attendants*

Each rider is permitted up to three attendants.

Passes are non transferable.

Riders must make their own arrangements for their supplies, including fuel, and for their pit attendants.

Every rider is responsible for ensuring that his pit attendants comply with official instructions and regulations and particularly the following rules:-

- Only at his/her pit may the rider get assistance or replenishment. Giving instructions to riders by signal or by word of mouth will not be regarded as assistance within the meaning of this regulation.
- Only the rider's own attendants may assist him/her.
- Only when the machine is at or approaching the pit may the attendants get out of the pit to help the rider. They may not go beyond the safety line i.e. first line in front of pits.
- The attendants may make any adjustments, replacements or repairs and may replenish the motorcycle and hand out food or drink to the rider but must not use any parts, supplies or tools, other than spare wheels and tyres, except those previously lodged in his/her pit.
- One or two attendants may help the rider to restart.
- The use of purpose-made front wheel paddock stands designed to support unaided the front of the motorcycle during refuelling is permitted. The use of ramps or other means to elevate the front of motorcycles during refuelling is forbidden.
- Pit attendants are strictly forbidden to sit or stand on refuelling gantries.
- Pit Attendants must wear fire retardant overalls and suitable footwear at all times in the pit lane.
- Footwear worn by attendants must adequately protect the foot and not contain any studs, steel tips or anything likely to cause a spark.
- Crossing of the pit lane will be permitted only at the top end of the pit lane and the crossing point will be closed during pit stops. Equipment may not be removed from pits until the end of the race except under official supervision.
- One attendant must remain in the pit at all times to receive messages.
- Remote starters will be allowed in the pit lane but must not be operated until refuelling and servicing is complete.

(3) *Pit Stops during races*

- With the exception of a rider having difficulty at the start of a race only, all pit stops will be made in the pit lane between the pits and the Grandstand.

Pit lane speed limit - 60kph

- At the entrance to the Pit Lane is a Single White Line with a board at each side indicating a speed limit of 60 kph. From this point until the Pit Lane Exit which is indicated by a White Line with a board at each side with the 60kph crossed out, the speed limit is 60kph.
- This speed limit will be policed by transponder loops in the Pit Lane.
- The following penalties will be issued to any competitor breaking the speed limit of 60kph and these penalties will be a matter of fact with no right of protest or appeal:-
 - *Over 60kph but not over 80kph - time penalty of 30 seconds*
 - *Over 80kph but not over 100kph - time penalty of 60 seconds*
 - *Over 100 kph - disqualification from the race*
- In the event of more than one infringement during a single Pit Stop the highest penalty will be awarded.
- At the entrance to the Pit Lane a display board will indicate the speed of competitors approaching the Pit Lane. This is only an indication to assist competitors.
- The lifting of the front wheel of a motorcycle for the purpose of showmanship (whether in the pit lane or on the course and whether in practice or in a race) may be deemed to be dangerous riding and may result in disqualification.

(c) **Finish of a race**

Riders who have completed the designated number of laps for the race will be shown a chequered flag by an official standing at the finish line. Riders crossing the finish line without completing the designated number of laps after the leading rider on the road has been shown the chequered flag may be permitted to proceed on a further lap. Where in the opinion of the Clerk of the Course it is no longer appropriate, he may order all competitors to stop as each crosses the finishing line. Riders not permitted to commence the final lap will be included in a partial classification established at the end of the penultimate lap of the race. Red lights will then be shown prior to the return road gate and a marshal showing a red flag will stand at the return road gate. The rider must be in contact with his/her machine.

(d) Stopping a Race

- A race will not be stopped prematurely unless the Clerk of the Course deems it necessary, but if so stopped before the leading competitor has completed half of the total race distance, the race will be declared abandoned. The finishing positions in an abandoned race will be ignored for the purpose of classification of the race result.
- A race stopped after the leading competitor has completed half of the scheduled race distance will be deemed to have been completed. The Clerk of the Course reserves the right to postpone or abandon any or all of the races if he considers it necessary.
- The Clerk of the Course may, notwithstanding the previous paragraphs, declare a result of any race based on such assessment as he thinks appropriate and, in doing so, may apply Section 10 of the ACU Standing Regulations for Road Racing to such extent (if any) as he thinks appropriate in the circumstances.
- In the event of the Clerk of the Course stopping a race prematurely due to 'force majeure' circumstances, waved red flags will be displayed at various points on the Course on the instructions of the Clerk of the Course or his Deputy. Stationary yellow flags will be displayed at intermediate marshals' posts. In the event of the Clerk of the Course shortening (as opposed to stopping) a race, this decision may be given to all riders at various points on the course. In these circumstances the chequered flag will be displayed at the start/finish line.

16. PROTESTS AND APPEALS

Protests against machine eligibility must be lodged on or before Friday 22 August.

Protests must be in accordance with the ACU National Sporting Code Chapter 10, and accompanied by a fee of £100. In addition if the dismantling of an engine is involved, a deposit of £250 for 4 strokes and £150 for 2 strokes must be submitted with the Protest Fee as per ACU Road Race Regulation 14.23.3. In the event of the protest being upheld the Deposit will be returned. If the protest is unsuccessful the deposit will be awarded to the winning party and will be the only cost claimable. The time limit for making a protest will be 30 minutes after the display of the provisional results on the Official Notice Board in the Race Office. The deposit for a fuel test will be £600.

17. WINNERS ENCLOSURE

At the conclusion of each race the first three finishers will be directed into the Winners Enclosure with their machines to conduct interviews with the host television and radio broadcasters. No other television or radio journalists will be permitted to operate in this area. The Winners Enclosure will be separated into four distinct zones and certain passes will allow access to certain areas of the Enclosure. See map below, see over for details.

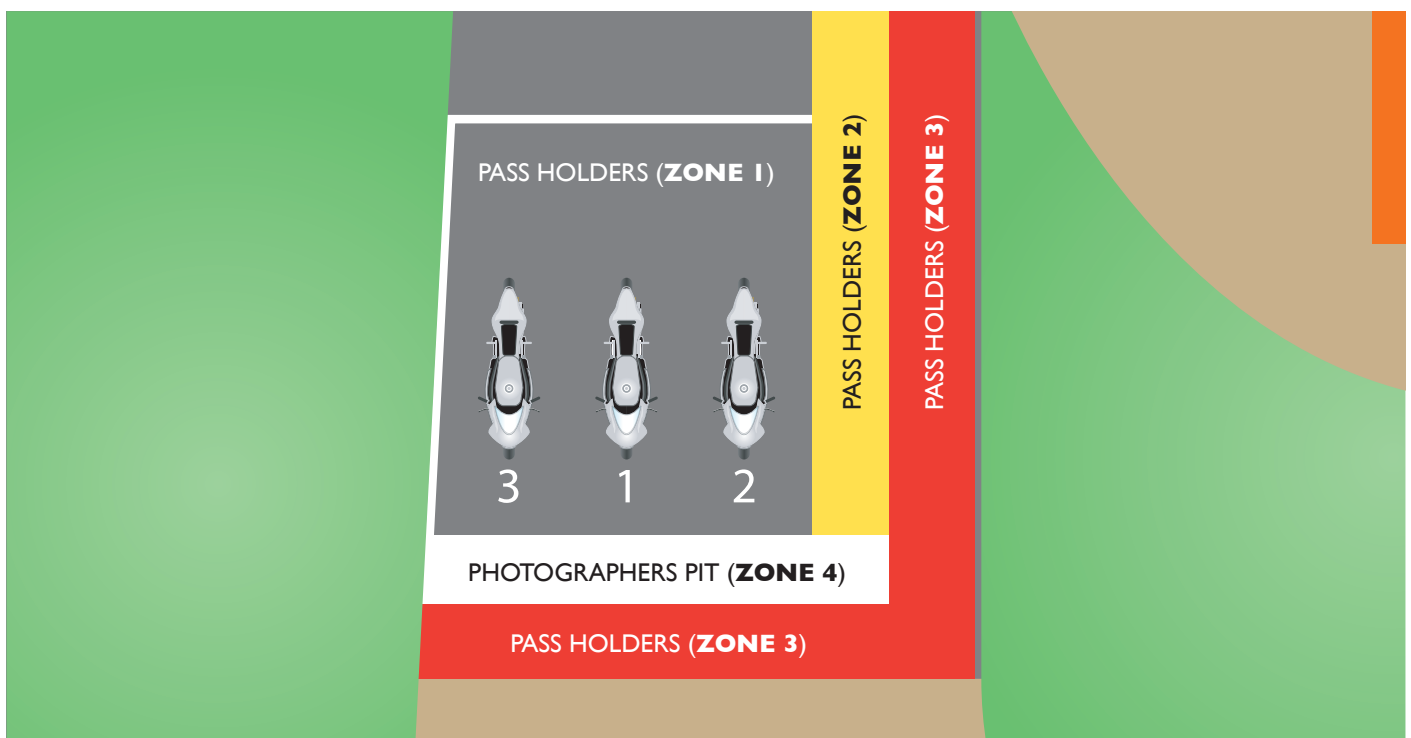

17. WINNERS ENCLOSURE (cont.)

The Winners Enclosure will be separated into four distinct zones and certain passes will allow access to the following areas:

Zone 1

Zone 1 is the area the first three finishing machines will be parked immediately post race. Zone 1 can be accessed by the following passes only –

- Official Pass (Red)
 - Promoter Pass (Black)
 - Race Mechanic Pass (Yellow)
 - Host Media (Blue)
 - The host television and host radio personnel will also be permitted in this area under the supervision of the Promoters.
-

Zone 2

Zone 2 can be accessed by the following passes only –

- Official Pass (Red)
 - Promoter Pass (Black)
 - Race Mechanic Pass (Yellow)
 - Team Personnel Pass (Cyan)
 - Host Media (Blue)
 - TV (White)
-

Zone 3

Zone 3 can be accessed by the following passes only -

- Official Pass (Red)
 - Promoter Pass (Black)
 - Race Mechanic Pass (Yellow)
 - Team Personnel Pass (Cyan)
 - Platinum VIP Pass (Silver)
 - Host Media (Blue)
 - TV (White)
 - Photographer (Pink)
 - Media (Media)
-

Zone 4

Zone 4 can be accessed by the following passes only -

- Official Pass (Red)
 - Promoter Pass (Black)
 - Host Media (Blue)
 - TV (White)
 - Photographer (Pink)
-

Outside of the main Enclosure will be two other areas. One will be clearly identified as a 'press pit'. The remaining area will can be accessed by individuals with other Passes.

18. GARLANDING CEREMONY

Riders finishing 1st, 2nd and 3rd in each race will be required to take part in a short ceremony to be held in front of the Grandstand to acclaim and garland the winners. This ceremony will take place approximately 10 minutes after the third placed competitor has entered the winners' enclosure.

19. AWARDS

For details of MGP awards see Appendix B and for details of Classic TT awards see Appendix C.

AWARD PRESENTATIONS

Details of the dates and venue will be included in Final Instructions.

20. TRANSPONDERS AND AUTOMATIC TIMING

- A separate transponder must be provided for each machine entered.
 - All practices and races will be officially timed using a transponder based automatic timing system.
 - It is the responsibility of each competitor to provide and properly fit a transponder; a fully charged AMBTranx 260 or a directly compatible equivalent, at his/her own expense.
 - The identification number(s) of the transponder(s) must be the same as the identification number(s) on the entry form for that machine and class. No additional Transponder/lap recorder device is permitted on the machine during practice or races. Any change to transponder identification must be approved by the Clerk of the Course at least one hour before the start of practice or race. **See also Appendix A.**
-

21. ON-BOARD CAMERAS AND GLOBAL POSITIONING SYSTEMS

- Only riders authorised by the Clerk of the Course will be permitted to film from on-board cameras, or to carry GPS on their machines. Onboard cameras must be fitted before attending technical inspections and helmet mounted cameras will not be permitted.
 - Applications must be made on the official 'Application to the Clerk of the Course' form. Where such approval is granted, the installation of a camera or GPS and associated equipment is further subject to approval of the Chief Technical Officer.
-

22. MOBILE PHONES

- The carrying and use of mobile phones in the Technical Inspections bays, the holding area and the pits is strictly forbidden unless the device is intrinsically safe.
-

23. Paddock

The paddock will be organised by the promoter and its appointed agent G4S (Isle of Man) Ltd.

The Paddock Manager for G4S (Isle of Man) Ltd will be Lloyd Mister

Tel: 01624 649016, Fax: 01624 649049, Mobile: 07624 483945, E-mail: lloyd.mister@im.g4s.com

- Parking of all team vehicles will be under the control of the Promoter and its appointed agent and all teams must respect the instructions received.
- Space will be allocated by the Promoter and its appointed agent based on the information submitted by competitors on their entry form. The paddock parking position will be made by the Promoter and its appointed agent and the decision will be final. Teams and / or competitors will receive notification of their paddock parking position on arrival.
- The Paddock will open at 09:00am Monday 11th August 2014
- The Paddock will be segregated into various areas into which teams will be entitled to bring certain vehicles.
- The entire Paddock area is a closed road and access will only be granted by displaying an official event permit.
- Cars will not be permitted in any part of the paddock in 2014. All cars will be required to park in the official event car park situated in Nobles Park.



Retailing

Teams and competitors are not permitted to retail any goods or services from the paddock area during the period including merchandise. Any team or competitor wishing to retail in the specific paddock trade area should contact Motorsport Promotions Ltd on 01624 667808. The Isle of Man Office of Fair Trading will carry out unadvertised inspections of the paddock area during the event and have the power to confiscate goods for sale by companies or individuals without an Isle of Man Non Residents Traders License.

Containers

Containers will not be allowed in the paddock.

Scooters

Scooters can be used for paddock transportation by riders and team personnel only (not children).

Health and Safety

All competitors and their associated persons must at all times comply with all the health and safety requirements applicable in the paddock and displayed on the Race Office notice board.

Fuel Storage

There will be a dedicated high octane fuel storage facility within the paddock. Teams and competitors using high octane fuel must contact the Paddock Manager for further information before sending any fuel to the Island. Teams and competitors using pump fuel are strongly advised to obtain fuel on the day it is to be used. Under no circumstance is more than 10 litres of fuel to be stored within any paddock (other than the official store).

Teams and competitors who are storing fuels off site, are reminded of their obligations to let the authorities on the Isle of Man know what fuel is being stored and where. It is the responsibility of all teams and competitors to remove all metal fuel containers to the skips provided in the paddock. Any off site fuel storage facility (more than 2 litres) will need to be licensed by the Isle of Man Office of Fair Trading. Please be aware that persons transporting large amounts of fuel may face prosecution if not appropriately licensed.

Competitors should consider how and when fuel is obtained for each qualifying session and race. Competitors using pump fuel are reminded that they should purchase the amount needed for that session or race and that they should not store more than is needed.

Fire Extinguishers

All competitors / race support / trade personnel using the paddock will need to supply a 2 Kg (minimum) dry powder fire extinguisher. The extinguisher must be visible at all times and have an in date certificate attached. Checks will be made during the event. All team members must be aware of its location and have knowledge in how it is operated.

Fire Points

Fire points are located within Paddocks A, B, C and D and all team members must be familiar with their location. All Fire points are alarmed and extinguishers should not be removed unless needed in an emergency.

Welding

The use of welding equipment within the paddock area is strictly forbidden. Under no circumstance should teams or competitors bring welding equipment in to the paddock or associated areas. Any equipment found may be confiscated.

Generators

Generators must be placed in a safe working area. All cables used from generators or the electrical supply, must be covered by proprietary cable protector at all times. The use of generators should be kept to a minimum during night time hours.

Electrical Supply

Under no circumstance should anyone interfere with the electric supply from the power masters in the paddock. If an electric supply fails, please contact the Paddock Manager in the first instance. Teams and competitors are required to have all electrical equipment PAT tested prior to use.

Security

The paddock will be patrolled by security guards. There are two, 24/7 security points which are fixed. There will be a foot patrol during daylight hours but no foot patrols between 19:00 hrs and 07:00 hrs.

Rubbish Removal

All competitors and team members are responsible for the removal of rubbish from parking and camping areas. Bins are provided for the disposal of bin bags located to the south of Paddock B.

Shower Block and Toilet areas

Showers and Toilet areas will be cleaned between the hours of 07:00 hrs to 21:00 hrs. All areas will be checked and cleaned regularly.

General Notice

A one way system will operate within the paddock. It has been designed for the smooth and safe transition of all vehicle movements. A 10 mph speed limit exists at all times. At no time should any vehicle block an entrance or exit.

24. PERSONNEL PASSES

There are different types of personnel passes depending on the activity of the pass holder providing access to various areas around the Start Line and Paddock.

 Competitor Wristband

 Official Pass (Red)

 Promoter Pass (Black)

 Race Mechanic Pass (Yellow)

 Team Personnel Pass (Cyan)

 VIP Guest Pass (Gold)

 Platinum VIP Guest Pass (Silver)

 Guest Pass (Orange)

 Event Support (Purple)

 Host Media Pass (Blue)

 TV Pass (White)

 Photographer Pass (Pink)

 Media Pass (Green)



Race Day Parc Ferme and Grid Pass



Race Day Winners Enclosure Pass

Competitors Wristband

The competitors wristband is issued to all competitors and is to be worn by the competitor when requiring access to the Parc Ferme, Start Line and Grid prior to the commencement of practice or racing. This will replace the requirement for the competitor to be in possession of a Mountain Course License to gain access to these areas during these periods.

Official Pass (Red)

The Official Pass is issued to the personnel who operate in roles on behalf of the Organisers and Promoters and will require access to all areas apart from the Parc Ferme, Grid and Winners Enclosure on race days, except Technical Officials who will be permitted in these areas. This pass will feature a passport size photograph of the pass holder. Anyone in possession of this pass is not permitted to use a camera in any of the pass holder areas.

Anyone in possession of this pass is not permitted to use a camera in any of the pass holder areas.

Promoter Pass (Black)

The Promoter Pass is issued to the personnel who operate in roles on behalf of the Promoters and will have access to all areas from the Parc Ferme, Grid and Winners Enclosure on race days. This pass will feature a passport size photograph of the pass holder. Anyone in possession of this pass is not permitted to use a camera in any of the pass holder areas.

Anyone in possession of this pass is not permitted to use a camera in any of the pass holder areas.

Race Mechanic Pass (Yellow)

The Race Mechanic Pass is issued to the personnel who work or do a professional activity on behalf of a race team during the event inside the restricted areas (Parc Ferme, Winners Enclosure, Start Line, Grid and including the Pit Lane).

Under no circumstances should Race Mechanic Passes be allocated or distributed to guests and any such passes will be withdrawn. Each solo rider and sidecar driver will be allocated a maximum of three Race Mechanic Passes.

Fire retardant overalls must be worn by all personnel in Pit Lane and this rule will be strictly enforced.

Anyone involved in the refuelling of machines in the Parc Ferme area must also wear fire retardant overalls. Footwear worn by Race Mechanic pass holders must adequately protect the foot and not contain any studs, steel tips or anything likely to cause a spark.

Anyone in possession of this pass is not permitted to use a camera in any of the pass holder areas.

Team Personnel Pass (Cyan)

The Team Personnel Pass is issued to the personnel who work or carry out a professional activity on behalf of a race team during the event inside the restricted areas (Parc Ferme, Winners Enclosure, Start Line and Grid). This pass does not grant access to the Pit Lane.

Under no circumstances should Team Personnel Passes be allocated or distributed to guests and any such passes will be withdrawn.

Anyone in possession of this pass is not permitted to use a camera in any of the pass holder areas.

VIP Guest Pass (Gold)

The VIP Guest Pass is issued by the Promoters and provides access to the Official Classic TT Hospitality facility. Additional access to the Start Line may be granted by the promoter and such access will be marked on the pass. There will be four VIP Guest Passes, one for each race day, and will only be valid for the race day identified on the pass.

This pass does not allow access to the Parc Ferme, Winners Enclosure, Grid or Pit Lane.

Platinum VIP Guest Pass (Silver)

The Platinum VIP Guest Pass is issued by the promoters and provides access to the Official Classic TT Hospitality facility, Parc Ferme, Winners Enclosure, Start Line and Grid. There will be four Platinum VIP Guest Passes, one for each race day, and will only be valid for the race day identified on the pass.

Holders of these passes will be accompanied by a representative of the Promoter at all times when inside the restricted areas.

Guest Pass (Orange)

The Guest Pass is issued by the organisers and/or promoters and provides access to the Start Line and Grid (Grid access is for practice periods only).

This pass does not grant access to the Parc Ferme, Winners Enclosure, Parc Ferme and Grid.

Event Support Pass (Purple)

The Event Pass is issued to the personnel who work or carry out a professional activity during the event inside the restricted areas who are not race officials.

This pass will have access to all areas apart from the Parc Ferme, Grid and Winners Enclosure on race days. This includes but is not restricted to personnel carrying out maintenance contractor work, cleaning and hospitality.

Host Media Pass (Blue)

The Host Media Pass is issued by the Chief Press Officer to personnel who work for a Media agency employed by the organiser and/or promoter. The Host Media pass will have access to all areas and pass holders will also be required to wear a blue Host Media tabard.

TV Pass (White)

The TV pass is issued by the Chief Press Officer to personnel working for independent TV production companies and TV news organisations who may need to work on the Start Line and Grid (Grid access is for practice periods only).

This pass does not grant access to the Parc Ferme, Winners Enclosure, Parc Ferme and Grid.

Photographer Pass (Pink)

The Photographer pass is issued to photographers accredited by the Chief Press Officer who may need to work on the Start Line and Grid (Grid access is for practice periods only).

This pass does not grant access to the Parc Ferme, Winners Enclosure, Parc Ferme and Grid.

Media Pass (Green)

The Media pass is issued to journalists accredited by the Chief Press Officer who may need to work on the Start Line and Grid (Grid access is for practice periods only).

This pass does not grant access to the Parc Ferme, Winners Enclosure, Parc Ferme and Grid.

Race Day Parc Ferme and Grid Pass

The Race Day Parc Ferme and Grid Pass, is a second pass to be worn on the lanyard providing access to the Parc Ferme and Grid on race days.

Race Day Winners Enclosure Pass

The Race Day Winners Enclosure Pass, is a second pass to be worn on the lanyard providing access to the Winners Enclosure on race days.

Pass General Rules

- *Teams and competitors are responsible for the integrity of the pass system within their team. Sanctions will be imposed on any team whose members abuse the pass system in any way including:*
 - *Selling passes*
 - *Production, sale or distribution of forged passes*
 - Teams and competitors are also responsible for the behaviour of their guests. Guests should be advised that they are expected to respect the instructions of race officials.
 - By accepting the issue of passes the team and / or competitor are deemed to agree to abide by the pass conditions and to undertake the obligation to advise each person to whom a pass is issued of the pass conditions and to ensure the observance thereof.
 - Passes may only be used to gain access to the areas indicated on the face of it. Any person found within a restricted area without the appropriate pass may be removed from the venue immediately and / or have any pass held by them withdrawn.
 - Passes must not be removed from their official lanyards and must be worn around the neck of the person to whom it is issued so as to remain clearly visible at all times.
 - The Organisers at all times reserve the right to refuse admission to the venue or access to a designated area to any person, notwithstanding that such person may have been issued with an appropriate pass.
 - Teams and competitors must keep accurate records of the numbers of passes that they issue to guests, this information must be available for audit by the Organisers at an event.
 - The Organisers reserve the right to request further proof of identity in addition to a pass.
 - Issued passes at all times remain the property of the Organisers and may be issued, altered or withdrawn at any time at the absolute discretion of the Organisers.
 - Team and competitor pass allocation will depend on the number of classes entered by the rider(s). The passes will be sequentially numbered and referenced for official use and riders and teams will be required to identify their teams pass holders on their entry form to allow the Organisers to allocate individual passes to individual persons.
-
-

25. VEHICLE RECOVERY SERVICE

A recovery service will operate throughout the practices and races. Any machines collected will be returned to the Technical Inspections Bay. The organisers do not accept any responsibility for any damage to any machine. Security is the responsibility of the competitor who must ensure that they or an attendant remains with the machine until collected.

26. ACCEPTANCE OF RECORDS

Entrants and riders must accept the official records of the Club, which may be published as the Club thinks fit and also agree not to publish or allow to be published, on their behalf, any inaccurate, misleading or premature advertisement in connection with these races.

27. BREACH OF REGULATIONS

The Clerk of the Course is empowered to impose penalties of a reprimand and/or fine, or disqualification, for breach of these regulations where no other penalty is specified. Any rider not complying with instructions of an official of the meeting (including security personnel employed by the promoter) may be penalised.

28. INDEMNIFICATION OF THE CLUB

It is one of the conditions upon which entries are accepted for these races that the Club will not be responsible for any damage that may be done to any competing motorcycle or to its accessories during the meeting, either by fire, accident or otherwise, nor for the theft of the motorcycle or any of its accessories except as provided by Regulation 8.

29. JURISDICTION

Each entry, if accepted, will form a contract between the Club and the entrant/rider, which will be governed by and construed in all respects in accordance with Isle of Man Law. Each of the parties irrevocably submits to the jurisdiction of the Isle of Man Courts in respect of any legal action or proceedings arising out of the contract or the participation of the entrant/rider in the meeting.

30. PUBLICITY

Each competitor, as requested, must make themselves available free of any charge or expenses to the Promoter during the event for promotional purposes.

Riders finishing first, second and third in each race shall attend the podium ceremony.

In submitting an entry each competitor and entrant agree that the promoter and the event sponsors may make use of his/her activities and successes in motorcycle sport for any advertising, publicity, public relations and merchandising purposes. All riders may be required to carry an event and/or sponsors logo.

31. MERCHANDISING

The competitor and entrant will authorise the Promoter to use and reuse and licence the use of images and representations of the competitor and team motorcycles competing in the event (including the manufacturer's name and logo), and the name, images and representations of the competitor and team and team paraphernalia including (in so far as the same appears on the clothing worn by the competitor or on team paraphernalia or on the motorcycles participating in the event) the logo and decals of all sponsors of the competitor and/or team for the purpose of producing merchandise exploiting the reputation of the event. The competitor and entrant acknowledge and agree that the Promoter and those authorised by it have the exclusive right to produce or authorise the production of interactive games of the event and games including individual elements of the event.

The competitor, entrant and/or team authorise the Promoter to use and licence others to use all event images and other material relating to the event in marketing and packaging material and commercial advertisements exploiting the event or merchandise of the event or any individual elements of the event.

The competitor and entrant shall assist the Promoter and those authorised by it with the promotion of the event and production and promotion of merchandise associated with the event.

32. MISCELLANEOUS

Riders, sponsors, manufacturers, entrants, and team personnel may not either individually or with any such participants or through any representative or agent, procure, solicit or arrange for any supplies, gratuities, products, merchandise, equipment or any other thing of value to be provided from any source whatsoever bearing or depicting the official Isle of Man Festival of Motorcycling logo(s) and/or any trademark and/or any copyright and/or image used or associated with the event without the prior written permission of the Promoter to do so.

All the broadcast, recording, terrestrial, cable, satellite, digital, video and rights in all other media (including but not limited to WAP or similar mobile communications platforms and/or devices, Internet, Interactive and/or other competitor accessed sources) to the Manx Grand Prix races are owned by the MMCC and are the subject of a licence granted by the MMCC to the promoter.

All the broadcast, recording, terrestrial, cable, satellite, digital, video and rights in all other media (including but not limited to WAP or similar mobile communications platforms and/or devices, Internet, Interactive and/or other competitor accessed sources) to the Classic TT Races are owned by the DED.

Any recording, broadcast, rebroadcast or reproduction without express permission of the Promoter is strictly prohibited. Competitors, entrants, sponsors or manufacturers currently registered in the event may, subject to the prior written permission of the Promoter and subject to any conditions that they may impose at their absolute discretion, be granted rights to use broadcast material for their own specific promotional use within the British Isles without fee or charge except any that may be levied for technical and or research purposes. Rights requested by sponsors, advertisers, or any other commercial use must be made in writing to the Promoter and will be subject to Licence, which may include a fee or charge.

33. USEFUL CONTACTS

Motorsports Team (Isle of Man Tourism)

Department of Economic Development
Upper Church Street
Douglas
Isle of Man, IM1 2PX
Tel: +44 (0) 1624 686802
Fax: +44 (0) 1624 686800
E-mail: iomtt@gov.im

Isle of Man Steam Packet Co Ltd

P O Box 5
Douglas
Isle of Man
Tel: +44 (0) 1624 661661
Fax: +44 (0) 1624 645608
E-mail: res@steam-packet.com

Doodson Broking Group

Lockton International
6th Floor, 19 Spring Gardens
Manchester, M2 1FB
Contact: Dawn Luby
Tel: +44 (0) 161 828 3326
Mobile: +44 (0) 7775-574863
Email: dawn.luby@uk.lockton.com

Trading Standards Division (Isle of Man)

Office of Fair Trading
Lord St, Douglas
Isle of Man
Tel: + 44 (0) 1624 686520
Fax: + 44 (0) 1624 686504

IOM Vintage Motor Cycle Club

The Old Vicarage
Main Road
Kirk Michael
Isle of Man
Tel: +44 (0) 1624 878242
Email: tonyeast@manx.net

Isle of Man MGP Press Office

The Grandstand
Glencrutchery Road, Douglas
Isle of Man
Tel: +44 (0) 1624 644622
Fax: +44 (0) 1624 644642
E Mail : mgp@manx.net

ACU

ACU Road Race Department,
ACU House
Wood Street
Rugby, CV21 2YX
Tel: +44 (0) 1788 566400
Fax: +44 (0) 1788 573585
E-mail: rr@acu.org.uk
www.acu.org.uk

Transponders available from:

AMB it
Zuiderhoutlaan 4
2012 PJ Haarlem
The Netherlands
www.amb-it.com

APPENDIX A - APPLICABLE TO ALL MACHINES

1 TYRES

Owing to variations in weather conditions which can occur on the TT Course and in the interests of safety, only tyres having a moulded tread pattern will be permitted. No additional cutting of moulded tyres will be permitted. No slicks, cut or uncut, will be allowed. Metal valve caps (not extractor type) or moulded racing valve caps which incorporate a pressure seal must be fitted. Valves must be of the short stub stem type.

2 OIL FILTERS

All spin-off oil filters must be jubilee clipped and wire locked.

3 WHEEL NUTS & SPINDLES

All wheel nuts and spindles must be wire locked or have split-pins. Where this is impractical, fork leg retaining/pinch bolts should be wired. Where forks have removable or pivoting wheel spindle retaining caps, the nuts or bolts holding these must be wire locked or otherwise positively retained.

4 BRAKES

- i) *Brake Lines: For machines fitted with two front disc brakes, the split of the front brake lines for both front calipers must be made at or above the lower fork.*
- ii) *Brake Calipers: Where the brake pad pin is retained by one fastener, a secondary retainer is required.*

5 PREPARATION

Must be in accordance with the ACU Standing Regulations and these Supplementary Regulations. The Club reserves the right to refuse any entry or to forbid the use of any particular machine which the Club considers inappropriate for racing on the TT course, or otherwise not to be in the spirit of this event. All machines must be prepared to a high standard of cosmetic appearance. Untidy machines will not be permitted to start in any event.

6 COOLANTS

No liquid engine coolants, other than lubricating oil or water should be used. Oil based substances can be dangerous if spilt on the road.

7 EXHAUST SPRINGS

All exhaust springs including those to the cylinder head must also be held by wire to ensure that the springs remain on the machine in the event of spring failure.

8 OIL CONTAINMENT

In the interests of safety Standing Regulations will be enforced.

9 SOUND

In the interests of safety Standing Regulations will be enforced.

10 CHAIN GUARDS

A chain guard must be fitted in such a way as to cover the point where the chain runs onto the rear sprocket and irrespective of wherever the rear wheel is positioned to maintain correct chain tension. The guard must be made of substantial material and must be securely mounted to the swinging arm so that it cannot rotate and come into contact with the chain or sprocket.

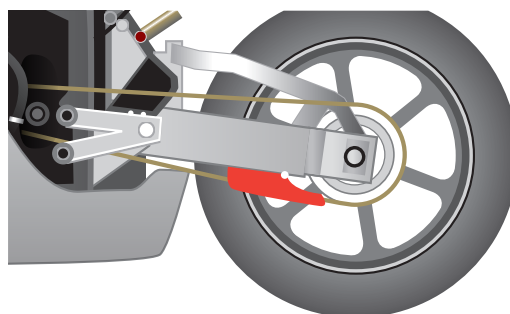

11 MONZA FILLER CAPS

All Monza filler caps must be fitted with an "R" clip or other device, to prevent unintentional opening of the cap. The device must be replaced after any pit stop.

12. TRANSPONDERS

- Ensure that the transponder holder is fitted securely, preferably using bolts and Nylock nuts (if tie-wraps are used at least two sufficiently strong tie wraps are needed to secure the holder)
- The transponder must be mounted VERTICALLY and NOT horizontally
- The securing pin must be at the top
- Fit the transponder holder in a safe and secure position
- Mount the transponder so that it is preferably no more than 2 ft (60 cm) from the ground
- Mount the transponder so that it is away from heat generating bodies such as the exhaust
- Mount the transponder so that it has as clear a view of the ground as possible. Note – the transponder signal will not pass through metal or carbon fibre based plastics
- Push the 'R' clip right through as far as possible in order to prevent it being accidentally pushed out
- The transponder must be fitted whenever your machine is taken into the assembly area and whenever it is on the course, including timed and untimed practice sessions
- The transponder must be charged and 'flashing' green and fitted to the machine when presented for Technical Inspections

PLEASE SEE TRANSPONDER DIAGRAM BELOW

Disregarding any of the above guidelines may result in your time(s) not being recorded.

No time will be recorded at all if the transponder is not fitted or has not been charged.

PREFERRED POSITIONS:

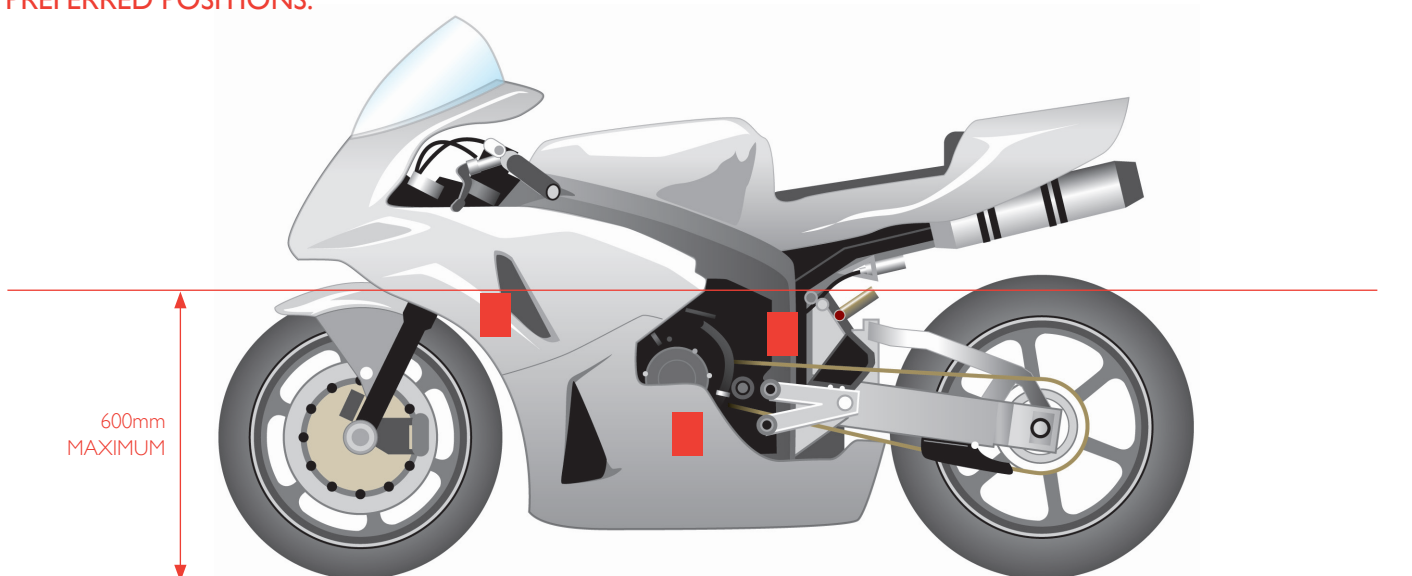

APPENDIX B - APPLICABLE TO MANX GRAND PRIX MACHINES ONLY

I. MACHINE ELIGIBILITY

(a) Riders (SuperTwin, Lightweight, Junior & Senior Manx Grand Prix)

- (i) Previous winners of the Lightweight, SuperTwin, Junior and Senior Manx Grand Prix Races will be Considered subject to (ii) below:-
- (ii) Riders who have previously competed in any TT solo or won a Manx Grand Prix race on the TT Mountain Course are NOT eligible if:-
- they have qualified to start in any TT solo or won a Manx Grand Prix race on the TT Mountain Course in the previous two years, eg a rider must not have qualified to start in a 2013 or 2014 TT solo race or won any Manx Grand Prix race in 2012 or 2013
 - they have won a silver replica in any TT solo race in the last four years, eg a rider who wishes to compete in the 2014 Manx Grand Prix must not have won a silver replica in any TT solo race on the TT Mountain Course from 2011-2014 inclusive.

Note – Should a rider be in doubt as to the status of any event he/she may have entered he/she should contact the Secretary of the Meeting.

(b) Machines

NEWCOMERS RACE in 3 classes

Class A

550cc – 750cc	4 stroke 4 cylinder
65 l cc – 1000cc	4 stroke 2 cylinder
60 l cc – 675cc	4 stroke 3 cylinder
50 l cc – 1000cc	rotary equivalent

Class B

20 l cc – 450cc	2 stroke 2 cylinder
Up to 650cc	4 stroke 2 cylinder

Class C

Up to 125 cc	2 stroke single cylinder; 6 gears maximum
25 l cc – 400cc	4 stroke, 4 cylinder: Rebore to a maximum increase of +1.00mm above the standard bore size are permitted.
Up to 750cc	4 stroke single cylinder

JUNIOR MANX GRAND PRIX RACE

20 l cc – 250cc	2 stroke 2 cylinder
550cc – 600cc	4 stroke 4 cylinder
60 l cc – 675cc	4 stroke 3 cylinder
65 l cc – 750cc	4 stroke 2 cylinder

SUPERTWIN/LIGHTWEIGHT MANX GRAND PRIX RACE in 2 capacity classes

Class A SuperTwin

20 l cc – 450cc	2 stroke 2 cylinder
Up to 650cc	4 stroke 2 cylinder

Class B Lightweight

Up to 125 cc	2 stroke single cylinder; 6 gears maximum
25 l cc – 400cc	4 stroke 4 cylinder: Rebore to a maximum increase of +1.00mm above the standard bore size are permitted
Up to 750cc	4 stroke single cylinder

SENIOR MANX GRAND PRIX RACE

550cc – 750cc	2/4 stroke 4 cylinder
65 l cc – 1000cc	4 stroke 2 cylinder
60 l cc – 1000cc	4 stroke 3 cylinder
50 l cc – 1000cc	rotary equivalent

If insufficient entries are received for any class, the Club may at its discretion amalgamate that class with any other class, and/or offer entrants the opportunity to transfer to another class and change their machines to one eligible for the other class.

(c) Fuel Tanks/Capacities

Each motorcycle must have only one fuel tank which must not hold more than 24 litres. The use of temporary filling material to reduce the capacity of the tank is forbidden.

2. ENTRY FEES AND PROCEDURE

- (a) MGP Entries may only be made online via the Manx Motor Cycle Club website www.manxgrandprix.org by Saturday 8 June with the appropriate insurance contribution (see below). See Reg 8 for non ACU & SACU Licence Holders.

ACU/SACU	Non ACU/SACU
£333 per race	£ 231 per race

- The insurance contribution for non ACU/SACU riders will be £231 as the cost of their personal accident insurance will not be paid by the Club.
- The MMCC reserves the right to refuse any entry and abandon, cancel or postpone the meeting or alter the programme of events and awards.

Unless, in the opinion of the Club, sufficient entries are received for a race, that race will not be held, in which case T will be returned. The Insurance Contribution may be returned in full if an entry is refused, but there is no other right to a refund and any given will be at the discretion of the organisers.

- For each race a maximum of 100 entries will be accepted, from which 90 will be permitted to race. The MMCC will nominate 10 reserves, who will replace non-starters based on the order of qualification times. The reserves will be notified as soon as possible whether they will have an opportunity to race. The maximum grid of 90 competitors will start singly in numerical order at 10 second intervals.
- Priority will be given to Manx Grand Prix Replica winners in the last two years.
- The remaining entries will be allotted at the MMCC's discretion.
- All Riders may apply for entries in more than one race providing they do not use the same machine on any one day. However Newcomers may not apply to enter two races run on the same day.

3. MGP AWARDS

- THE MANX GRAND PRIX TROPHY donated by A B Crookall to the winner of the Senior race.
- THE JUNIOR MANX GRAND PRIX TROPHY donated in memory of Douglas Pirie to the winner of the Junior race.
- THE LIGHTWEIGHT MANX GRAND PRIX TROPHY donated by Motor Cycle to the winner of the Lightweight race.
- THE ULTRA LIGHTWEIGHT MANX GRAND PRIX TROPHY donated in memory of Albert Moule to the winner of the SuperTwin race.
- THE AITCHESON TROPHY to the winner of Class A of the Newcomers race.
- THE BRADDAN BRIDGETROPHY to the winner of Class B of the Newcomers race.
- THE WAYNE HAMILTON TROPHY to the winner of Class C of the Newcomers race.
- THE LORD WAKEFIELD CUP to the rider making the best overall performance in the Junior and Senior races who is not a winner of either race.
- THE LADY HILL ROSE BOWL to the rider who is a local resident making the best performance during the Senior race.
- THE YORK TROPHY to the rider who is a local resident making the best performance during the Junior race.
- THE RAY COWLES TROPHY to the rider in any Manx Grand Prix race (but excluding the Newcomers Race) who makes the best performance on a 4 stroke machine of British manufacture.
- THE WALLACE CUP to the rider who is a local resident making the best performance during the Newcomers race.
- THE LESLEY ANNE TROPHY to the female rider making the best performance during the Manx Grand Prix races.
- THE CROMIE McCANDLESS TROPHY to the rider who is an Irish resident making the best during the Manx Grand Prix races.
- THE NORRIE WHYTE TROPHY to the rider who is a Scottish resident making the best performance during the Manx Grand Prix races.
- THE SEYMOUR TROPHY to the rider who is a National of a European country outside the British Isles making the best performance during the Manx Grand Prix races.

- THE MARTIN SMITH TROPHY to the rider who is a newcomer making the best performance during the Senior race.
- THE ALAN HAMPTON TROPHY to the rider who is a newcomer making the best performance during the Junior race.
- THE DAVE CORLETT TROPHY to the rider who is a newcomer making the best performance during the SuperTwin race.
- THE PHILIP HAYHURST TROPHY to the rider who is a newcomer making the best performance during the Lightweight race.
- THE HOGG TROPHY to the rider who is a local resident making the fastest lap during the Manx Grand Prix.
- A MEDAL will be presented to the rider of the highest placed 125 cc machine in the Lightweight race.
- A MEDAL will be presented to the rider of the highest placed 250 cc machine in the Junior race.
- THE GJA BROWN CLUB TEAM TROPHY to the Club having the winning team in the Senior race.
- THE JW DAVIE CLUB TEAM TROPHY to the Club having the winning team in the Junior race.
- THE BILLS/HARDING CLUB TEAM TROPHY to the Club having the winning team in the SuperTwin race.
- THE CASTLE HILL CUP to the Club having the winning team in the Lightweight race.
- THE PADGETT TROPHY to the Club having the winning team in the Newcomers race.
- THE DICKIE DALE TROPHY to the rider making the fastest lap in the Senior race.
- THE G D HANSON TROPHY to the rider making the fastest lap in the Junior race.
- THE FREDDIE FRITH TROPHY to the rider making the fastest lap in the SuperTwin race.
- THE PAM CANNELL TROPHY to the rider making the fastest lap in the Lightweight race.
- THE DUNCAN MUIR AND VAL CONATY TROPHY to the rider making the fastest lap in Class A of the Newcomers Race
- THE JEFFERIE TROPHY to the rider making the fastest lap in Class B of the Newcomers race.
- THE SEAN JACKSON AWARD to the rider making the fastest lap in Class C of the Newcomers race.

PLEASE NOTE: The above MGP awards (except medals for the highest placed 125cc in the Lightweight and 250cc in the Junior races) will remain in the custody of the Club after the presentation.

Replicas will be awarded to the 1st, 2nd & 3rd in all classes. Subsequent replicas will be awarded as follows:-

- In the Newcomers, SuperTwin, Lightweight, Junior and Senior races to those riders who finish within 11/10ths of the time taken by the respective winners or class winners;
- Club teams shall consist of 3 riders being fully paid up members of one or more Clubs affiliated to the ACU, SACU, MCUI or another national federation nominated by or on behalf of such club or Recognised Association on the form obtainable from the Race Office. The completed form should be lodged at the Race Office no later than 12 noon on the day preceeding the race day with a fee of £30. Any application for changes must be lodged with the Race Office no later than 12 noon on the day preceding the race. In the case of a postponement of a race to another day, one or more riders may be substituted not later than 17:00 hours on the day preceding the day to which the race is postponed. The winning club team will be decided on an aggregate basis. A club may enter more than one team but no rider shall be nominated for more than one team in any race.
- Each member of the winning team and the rider putting up the fastest lap in each of the races will receive an award. Medals will be presented to the winners of fastest lap trophies and other special awards. Finishers' medals will be awarded to riders who complete any race in compliance with the regulations but fail to qualify for any of the premier awards or replicas.

PLEASE NOTE: It is a condition of receiving any award that the winner/s of the award shall attend to receive the award unless excused by the Club for a good reason.

AWARD PRESENTATION

Details of the date and venue will be included in Final Instructions.

APPENDIX C - APPLICABLE TO CLASSIC TT MACHINES ONLY

I. MACHINE ELIGIBILITY

- The organisers retain the ability to accept an entry for a machine that is not compliant with these regulations if in their view it will enhance the spectacle of the racing without giving a competitor an unfair advantage. Such requests must be made in writing prior to the closing date for entries and will be accepted or rejected on a case by case basis.

I.1 CLASSIC TT 500CC AND 350CC CLASSIC TT RACES ELIGIBILITY

The 500cc Classic TT Race

- 351cc - 500cc Machines
-

The 350cc Classic TT Race

- 175cc - 350cc Machines
-

The Following is applicable to machines up to 500cc in the Classic Races

- The 500cc and 350cc Classic TT Races cater primarily for thoroughbred Grand Prix racing motorcycles constructed during:
 - (i) The period 01/01/1945 – 31/12/1972 inclusive, for all 4 strokes up to 500cc;
 - (ii) The period 01/01/1945 – 31/12/1967 inclusive, for all 2 strokes (with the addition of Greeves Oulton and Bultaco TSS built before 31/12/1968) for the specific purpose of participation in competition during that era.
-

I.2 FORMULA 1 AND FORMULA 2 CLASSIC TT ELIGIBILITY

The Formula 1 Classic TT Race

- Up to 1300cc, air-cooled 4-stroke Machines 01/01/1973 - 31/12/1986
 - Up to 1300cc, liquid/air-cooled* 4-stroke Machines 01/01/1973 - 31/12/1986
 - 700cc - 750cc 4-stroke, 4 cylinder Machines 01/01/1987 - 31/12/1992
 - Up to 1000cc 4-stroke, 2 and 3 cylinder Machines and Norton rotary-engined machines 01/01/1987 - 31/12/1992
 - 351cc - 750cc 2 stroke Machines 01/01/1968 - 31/12/1992
-

The Formula 2 Classic TT Race

- Up to 750cc 4 stroke, 2 cylinder Machines 01/01/1973 - 31/12/1986
- Up to 600cc 4 stroke, 4 cylinder Machines 01/01/1973 - 31/12/1986
- 126cc -350cc 2 Stroke Machines 01/01/1968 - 31/12/1992

1.3 GENERAL CONSIDERATIONS

- In formulating these Classic Regulations, the organisers have endeavored to produce races for machines built using components available in the eligibility periods. When looking at entries, consideration will be given to the period appearance of the machine as well as adherence to the letter of these regulations.
- Machines may also incorporate components of a type manufactured before the 31st December cut-off date or manufactured after that date without substantial alteration. Competitors are expected to present machines with visible components (e.g. wheels) generally similar to a type available in the period.
- All components fitted must be of a type available and fitted to machines of the relevant classes within the relevant classic period, defined below. This includes all major components such as frame, forks, wheels etc. No modifications (other than those specifically authorised in these regulations) will be permitted unless used during the period.
- Where components are of later manufacture, they must resemble the original period components.
- The onus is on the rider or entrant to prove eligibility if required.
- Entries will not be accepted without a specification sheet for each machine entered and with photographs, with and without fairing, if applicable. Riders who are in any doubt about eligible components or modifications are invited to contact the Chief Eligibility Officer for a ruling.

1.4 OIL CONTAINMENT

- Oil Containment is compulsory for all 4 stroke machines (i.e. faired and un-faired). The oil containment must be of rigid construction fastened securely to the machine and have a capacity of at least half of the total oil (and coolant) capacity in the event of an engine failure. The oil containment for un-faired machines must be at least 50mm deep and at the front must extend upwards to at least 50mm below the base of the cylinder except in the case of horizontal cylinder machines (eg Aermacchi) which will be subject to the agreement of the Chief Technical Officer whose decision is final.

1.5 SEAT, TANK AND FAIRING

- Motorcycles must be presented in period condition. Seats, tanks and fairings (if fitted) must be of a style and type manufactured and used in the appropriate period. Each motorcycle must have only one fuel tank which must not hold more than 24 litres. However Formula 1 TT machines may use fuel tanks holding not more than 29 litres. The use of temporary filling material to reduce the capacity of the tank is forbidden.

Rules 1.6 – 1.15 apply to machines up to 500cc racing in the 500cc Classic TT and 350cc Classic TT races only

1.6 WHEELS

- Must be of a wire-spoked construction and of 18" or 19" diameter. A maximum rim width of WM3 applies for Classic classes i.e. up to 500cc machines. Cast wheels will not be permitted, except for the Arter Matchless.

1.7 TYRES

- Owing to variations in weather conditions which can occur on the TT Course and in the interests of safety, only tyres having a moulded tread pattern will be permitted. No additional cutting of moulded tyres will be permitted. No slicks, cut or uncut, will be allowed. Metal valve caps (not extractor type) must be fitted. Valves must be of the short stub stem type.

Note for Classic machines only:

Maximum tyre width, as stated on the manufacturer's specification sheet, shall be 4.50" (114mm) for Classic machines (i.e a tyre described as a 110, 120 or 130 is not allowed). Tyres must be fitted with inner tubes.

1.8 BRAKES

- May be drum or disc for 4 strokes
- Only drum brakes may be used for Classic 2 strokes.
- All disc brake components must be pre-31/12/1972 for 4 strokes.
- Floating discs and/or 4 piston calipers will not be permitted.

- Discs must be solid and may be drilled only parallel to the wheel spindles. An unmodified out-of-period AP front brake master cylinder; part no CP3179-2 (plastic reservoir) is eligible, as is the AP Racing variable ratio front brake master cylinder parts no CP 3125-2 or CP 3125-4. The Grimeca front master cylinder as used on the Ducati 750 in 1972 is also acceptable.
- Where a rider has a genuine reason for not being able to operate a conventional brake lever; a thumb operated brake lever will be permitted. Due to space constraints, this may mean that an out of period master cylinder will be required. The use of such a device must be stated on the eligibility form and will be subject to prior approval by the Chief Technical Official.

1.9 SWINGING ARM, SUSPENSION AND FRONT FORKS

- Must be of a pattern, type and material manufactured and used in the period.

1.10 CARBURETORS

- Free choice of carburetor; with the exception of the following that are not permitted:
 1. Power jet carburetors
 2. Flat-slide carburetors (except Gardner carburetors)
 3. Fuel injection

1.11 ENGINE AND GEARBOX

- May be modified internally and/or fitted with components of modern manufacture. All engine and gearbox casings must be unmodified externally, except modifications carried out in the period, to permit the fitment of belt primary drives, or to permit the repositioning of controls. All primary drives (belt and chain) must be totally concealed from view. Multi-valve heads are not permitted, unless available and used in the era. Non-period components, e.g. engine castings, oil filter castings, cylinder barrels and expansion chambers will not be permitted. External oil pumps are not permitted. Engines may be rebored up to the machine manufacturer's recommended maximum oversize but no more than 1.5mm+ (0.060") if the actual capacity would then exceed the capacity class size.

1.12 CLUTCH

- Any clutch can be used but slipper clutches are not permitted

1.13 FRAMES AND REPLICA FRAMES

- The frame should be what was used for the machine in the period. Replica frames will be permitted provided they are dimensionally accurate copies of known period chassis. For chassis without known pedigree, entries must be supported by documentary evidence proving eligibility.

1.14 EXHAUSTS

- Must comply with ACU Standing Regulations

1.15 IGNITION SYSTEM

- There is no restriction on the type of ignition system used. If non-standard electronic units are used, components should be concealed where possible.
- Rules 1.16 – 1.26 apply to Formula 1 Classic & Formula 2 Classic machines only

1.16 WHEELS

- Free choice – as many machines of this era will have used magnesium alloy wheels which are subject to metal fatigue over time, in the interests of safety and availability, modern wheels that closely resemble what was used on the bike in the period may be used.
- Free choice of size.

1.17 TYRES

- Owing to variations in weather conditions which can occur on the TT Course and in the interests of safety, only tyres having a moulded tread pattern will be permitted. No additional cutting of moulded tyres will be permitted. No slicks, cut or uncut, will be allowed. Metal valve caps (not extractor type) must be fitted. Valves must be of the short stub stem type.
- Free choice of size with no maximum tyre size requirement.

1.18 BRAKES

- Free choice of brake caliper and master cylinder (including radial master cylinders but excluding radial calipers and carbon-fibre brakes)

1.19 SWINGING ARM, SUSPENSION AND FRONT FORKS

- Suspension systems must resemble the type available and fitted in the relevant period for the machine (subject to the replacement of shock absorbers). Modifications can be made to allow a different size tyre to be used.

1.20 CARBURETORS AND AIRBOX

- Free of restriction, but only if used within the period (i.e. if a machine did not have an airbox in the period, use of an airbox is not permitted; however, if a different make of carburetor was available in the period, it can be used).

1.21 ENGINE AND GEARBOX

- All engine and gearbox casings must be unmodified externally*, except modifications carried out in the period. May be modified internally and fitted with components of modern manufacture. Engines may be rebored but no more than 1.5mm+ (0.060") if the actual capacity would then exceed the capacity class size.
- Engines must be complete and as originally produced by the manufacturer.

**Note: Formula 2 two-stroke Yamaha machines will be allowed to use the later 4DP cylinders, which externally look the same as the earlier 4DP00 version*

1.22 CLUTCH

- Any clutch can be used. Slipper clutches are allowed.

1.23 FRAMES AND REPLICA FRAMES

- The frame should be what was used for the machine in the period. Replica frames will be permitted provided they are dimensionally accurate copies of known period chassis. For chassis without known pedigree, entries must be supported by documentary evidence proving eligibility.

1.24 EXHAUSTS

- Must comply with ACU Standing Regulations

1.25 IGNITION SYSTEM

- There is no restriction on the type of ignition system used.

1.26 ENGINE AND FRAME NUMBERS (F1 and F2 machines only)

- All solo road race machines are required to have engine and frame numbers that have obviously not been tampered with or deleted. The penalty is disqualification. New unstamped components are permissible.

2. ENTRY PROCEDURE & ENTRY FEES

- Applications for Classic TT Race entries must be made online via the competitors' section of www.iomtt.com no later than Monday 31 March 2014. Any entries received after the closing date may not be accepted.
 - For each race a maximum of 100 entries will be accepted, from which 90 will be permitted to race. The MMCC will nominate 10 reserves, who will replace non-starters based on the order of qualification times. The reserves will be notified as soon as possible whether they will have an opportunity to race. The maximum grid of 90 competitors will start singly in numerical order at 10 second intervals.
 - The promoters will cover the cost of the insurance contribution necessary to enter the 2014 Classic TT Races.
 - Applicants will be advised as soon as possible after the closing date of entries, whether or not they have been accepted.
 - The organisers reserve the right to refuse any entry.
-
-

3. RIDER STATUS AND RACE SUB CLASSES

To ensure competitors of all abilities and experience and machinery of varying specifications can compete in the Classic TT Races in an environment that promotes equality and sportsmanship, a number of sub classes have been created for each Classic TT Race.

The sub classes will be used to determine the awarding of replicas and other trophies, will be clearly identified in the official results and detailed in the official post-race press reports. Qualification for individual riders will be based on the sub classes.

Furthermore each competitor will be allocated either a rider status of either GP Rider or Privateer Rider:

The competitor sub class categories have also been redefined for 2014. Changes for 2014 will see the qualification for the 'GP Rider' sub class be defined as follows:

- A rider who has finished in 1st, 2nd or 3rd in a 500cc, 350cc, Formula 1 or Formula 2 Classic TT Race in any of the previous two years.
- A rider who has lapped at a threshold speed in a 500cc, 350cc, Formula 1 or Formula 2 Classic TT Race in any of the previous two years. These threshold speeds will be 105mph in 500cc, 100mph in 350cc, 115mph in Formula 1 and 108mph in Formula 2.
- A rider who has finished in the top 20 in a Superbike, Supersport, Superstock or Senior TT Race in any of the previous two years.
- In exceptional circumstances any other rider at the promoters discretion based on their experience and machinery.

The race sub classes will be as follows –

500cc Classic TT Race

Class 500GP1	301cc–500cc Single Cylinder and Push Rod Twin Cylinder Machines ridden by GP status Riders
Class 500P1	301cc–500cc Single Cylinder and Push Rod Twin Cylinder Machines ridden by Privateer status Riders
Class 500GP2	301cc–500cc Multiple Cylinder Machines ridden by GP status Riders
Class 500P2	301cc–500cc Multiple Cylinder Machines ridden by Privateer status Riders

350cc Classic TT Race

Class 350GP1	300cc - 350cc Single Cylinder Machines ridden by GP status Riders
Class 350P1	300cc - 350cc Single Cylinder Machines ridden by Privateer status Riders
Class 350GP2	300cc - 350cc Multiple Cylinder Machines ridden by GP status Riders
Class 350P2	300cc - 350cc Multiple Cylinder Machines ridden by Privateer status Riders
Class 250 175cc - 250cc	Two Stroke Machines ridden by either status Riders

Formula 1 TT Race

Class FIGP1	Pre 31/12/1986 air-cooled Machines ridden by GP status Riders
Class FIP1	Pre 31/12/1986 air-cooled Machines ridden by Privateer status Riders
Class FIGP2	Pre 31/12/1986 liquid Machines and pre 31/12/1992 Machines ridden by GP status Riders
Class FIP2	Pre 31/12/1986 liquid Machines and pre 31/12/1992 Machines ridden by Privateer status Riders
Class FC	Pre 31/12/1974 Machines ridden by either status Riders

Formula 2 TT Race

Class F2GP1	Pre 31/12/1986 2 Stroke Machines ridden by GP status Riders
Class F2P1	Pre 31/12/1986 2 Stroke Machines ridden by Privateer status Riders
Class F2GP2	Pre 31/12/1992 2 Stroke Machines ridden by GP status Riders
Class F2P2	Pre 31/12/1992 2 Stroke Machines ridden by Privateer status Riders
Class F2GP3	Pre 31/12/1986 4 stroke, 2 cylinder Machines ridden by GP status Riders
Class F2P3	Pre 31/12/1986 4 stroke, 2 cylinder Machines by Privateer status Riders
Class F2GP4	Pre 31/12/1986 4 stroke, 4 cylinder Machines ridden by GP status Riders
Class F2P4	Pre 31/12/1986 4 stroke, 4 cylinder Machines by Privateer status Riders

4. AWARDS

- THE 500cc CLASSICTT RACETROPHY to the winner of the 500cc Classic TT Race
 - THE 350cc CLASSICTT RACETROPHY to the winner of the 350cc Classic TT Race
 - THE 250cc CLASSICTT RACETROPHY to the winner of the 250cc Classic TT Race
 - THE FORMULA 1 CLASSICTT RACETROPHY to the winner of the Formula 1 Classic TT Race
 - THE FORMULA 2 CLASSICTT RACETROPHY to the winner of the Formula 2 Classic TT Race
 - THE FORMULA CLASSICTT RACETROPHY to the winner of the Formula Classic TT Race
 - THE JOEY DUNLOP CLASSICTT TROPHY to the rider of the first 750cc machine to finish in the Formula 1 Classic TT Race.
 - THE MIKE HAILWOOD CLASSICTT TROPHY to the rider of the first 500cc single cylinder machine in the 500cc Classic TT Race.
 - THE GEOFF DUKE CLASSICTT TROPHY to the rider of the first 350cc single cylinder machine in the 350cc Classic TT Race.
 - THE PHIL READ CLASSICTT TROPHY to the rider of the first 250cc machine in the 350cc Classic TT Race.
 - SILVER REPLICAS will be awarded to the riders finishing within 105% of the winner's time (per sub class).
 - BRONZE REPLICAS will be awarded to the riders finishing within 110% of the winners time but not qualifying for a silver replica (per sub class).
 - FINISHERS MEDALS will be awarded to all other finishers.
-
-

5. APPEARANCE FEES

Competitors competing in the Classic TT Races will be able to apply for appearance fees by providing information and justification to support the application to the promoters.

Any payments to riders and teams will be negotiated directly between the promoters and authorised representatives of the individual riders and teams.

The following items will provide the basis for the payment criteria –

- Potential media coverage value (team and / or rider) achievable before, during and after event
- Demonstrable ability to promote the Classic TT and Isle of Man positively (team and / or rider)
- Previous performance at the TT and Classic MGP Races (team and / or rider)
- Previous recent performance at other high profile motorcycle international and domestic racing
- Size and scale of team (infrastructure etc) and presentation

The above list is neither exhaustive nor absolutely definable and should only be used as a guide.

No applications will be considered after the 31st of March 2014.

SUMMARY OF TIMES

1. SIGNING ON - PRE PRACTICE

- Friday 15 August 15:00 hrs – 19:00 hrs (All riders including Newcomers)
- Saturday 16 August 09:00 hrs – 09:30 hrs (Newcomers only)
09:30 hrs – 11:30 hrs (All other riders)

2. BRIEFINGS

(a) Riders Briefings

- Friday 15 August 16:00 / 17:00 / 18:00 hrs (Newcomers only / 19:30 hrs)
- Saturday 16 August 10:00 (Newcomers Only) / 11:00 / 12:00 (All other riders)
- Monday 18 August 16:00 hrs

All Newcomers must arrive, sign on, and attend the Newcomers briefing at 18:00 hrs on Friday 15 August or 10:00 hrs on Saturday 16 August or they may be disqualified.

(b) Technical Briefings

- MGP riders at 13:15 hrs
- Classic TT riders at 14:00 & 14:45 hrs

(c) Newcomers' Pre-Race Briefing

- Pit lane briefings will be held for Classic TT and MGP Newcomers on Thursday 21 August at 11:00 hrs in the Pit Lane area if dry and Technical Inspections Bay if wet. This briefing is compulsory.

(d) MGP Newcomers' Post Race Briefing

- A briefing will be held on Tuesday 26 August at 11:00 hrs (Newcomers A/B/C) in the Conference Suite. This is compulsory.

3. TECHNICAL INSPECTIONS

Pre Practice

Saturday 16 August	15:00 - 15:45	Newcomers inc Classic TT Newcomers
	15:45 - 18:30	Senior; Junior; SuperTwin (No Newcomers)
	17:15 - 19:45	Classic TT, Lightweight
Monday 18 August	16:00 - 18:45	Senior; Junior; SuperTwin (No Newcomers)
	17:15 - 19:45	Classic TT, Lightweight, All Newcomers
Tuesday 19 August	16:00 - 18:45	Classic TT, Lightweight, Newcomers B/C
	17:15 - 19:45	Senior; Junior; SuperTwin, Newcomers A
Wednesday 20 August	16:00 - 18:45	Senior; Junior; SuperTwin, Newcomers A
	17:15 - 19:45	Classic TT, Lightweight, Newcomers B/C
Thursday 21 August	16:00 - 18:45	Classic TT, Lightweight, Newcomers B/C
	17:15 - 19:45	Senior; Junior; SuperTwin, Newcomers A
Friday 22 August	16:00 - 18:45	Classic TT, Lightweight, Newcomers B/C
	17:15 - 19:45	Senior; Junior; SuperTwin, Newcomers A
Saturday 23 August	08:00 - 09:30	350 Classic TT, F1 & F2 Classic TT
	12:30 - 14:15	Newcomer A, Senior; Junior; SuperTwin,
	14:15 - 15:00	Newcomer B/C, Lightweight
Monday 25 August	15:00 - 16:45	Senior; Junior; SuperTwin, Lightweight
Wednesday 27 August	12:30 - 14:00	Senior

SUMMARY OF TIMES

4. TECHNICAL INSPECTIONS

Pre Race

Saturday 23 August

500cc Classic TT

Nos 61 - 90	10:30 - 11:00 hrs
Nos 31 - 60	11:00 - 11:30 hrs
Nos 1 - 30	11:30 - 12:00 hrs

Monday 25 August

350cc Classic TT

Nos 61 - 90	08:00 - 08:30 hrs
Nos 31 - 60	08:30 - 09:00 hrs
Nos 1 - 30	09:00 - 09:30 hrs

Formula 1 & 2 Classic TT

Nos 61 - 90	10:00 - 10:30 hrs
Nos 31 - 60	10:30 - 11:00 hrs
Nos 1 - 30	11:00 - 11:30 hrs

Newcomers MGP

Nos 61 - 90	13:00 - 13:30 hrs
Nos 31 - 60	13:30 - 14:00 hrs
Nos 1 - 30	14:00 - 14:30 hrs

Wednesday 27 August

Junior MGP

Nos 61 - 90	08:00 - 08:30 hrs
Nos 31 - 60	08:30 - 09:00 hrs
Nos 1 - 30	09:00 - 09:30 hrs

SuperTwin/Lightweight MGP

Nos 61 - 90	10:00 - 10:30 hrs
Nos 31 - 60	10:30 - 11:00 hrs
Nos 1 - 30	11:00 - 11:30 hrs

Friday 29 August

Senior MGP

Nos 61 - 90	09:00 - 09:30 hrs
Nos 31 - 60	09:30 - 10:00 hrs
Nos 1 - 30	10:00 - 10:30 hrs

Any application for extension must be made during the times stated above

SUMMARY OF TIMES

5. RACE TIMES

- 45 minutes before the start. Riders take possession of machines in holding area
- 15 minutes before the start. Riders marshalled to starting grid.
- 5 minutes before the start. Stand to. Clear grid.

Saturday 23 August – Classic TT Race Day 1

13:00 hrs	Race CTT1	The 500cc Classic TT Race	(4 laps)
-----------	-----------	---------------------------	----------

Monday 25 August – Classic TT Race Day 2

10:15 hrs	Race CTT2	The 350cc Classic TT Race	(4 laps)
-----------	-----------	---------------------------	----------

13:30 hrs	Race CTT3	The Formula 1 Classic TT Race	(4 laps)
-----------	-----------	-------------------------------	----------

13:30 hrs	Race CTT4	The Formula 2 Classic TT Race	(4 laps)
-----------	-----------	-------------------------------	----------

(Races 3 & 4 will run concurrently)

15:45 hrs	Race MGP1	The Newcomers Race A	(4 laps)
-----------	-----------	----------------------	----------

15:45 hrs	Race MGP2	The Newcomers Race B	(4 laps)
-----------	-----------	----------------------	----------

15:45 hrs	Race MGP3	The Newcomers Race C	(4 laps)
-----------	-----------	----------------------	----------

(Races 1, 2 and 3 will run concurrently)

Wednesday 27 August – Manx Grand Prix Race Day 1

10:15 hrs	Race MGP4	The Junior Manx Grand Prix Race	(4 laps)
-----------	-----------	---------------------------------	----------

13:15 hrs	Race MGP5	The SuperTwin Manx Grand Prix Race	(4 laps)
-----------	-----------	------------------------------------	----------

13:15 hrs	Race MGP6	Lightweight Manx Grand Prix Race	(4 laps)
-----------	-----------	----------------------------------	----------

(Races 5 and 6 will run concurrently)

Friday 29 August – Manx Grand Prix Race Day 2

11:30 hrs	Race MGP7	The Senior Manx Grand Prix Race	(4 laps)
-----------	-----------	---------------------------------	----------

