



ISLE OF MAN

2010 INTERNATIONAL ISLE OF MAN TOURIST TROPHY RACES

REGULATIONS

CONTENTS

1	ANNOUNCEMENT	Page 1
2	OFFICIALS	Page 1
3	COURSE	Page 2
4	RACE PROGRAMME	Page 2
5	ELIGIBILITY	Page 2
6	ENTRIES	Page 3
7	TRAVEL ALLOWANCE AND APPEARANCE FEES	Page 4
8	PADDOCK	Page 5
9	PASSES	Page 9
10	INSURANCE AND MACHINES ON PUBLIC HIGHWAY	Page 11
11	SIGNING-ON / BRIEFING	Page 12
12	TECHNICAL INSPECTIONS	Page 13
13	FLAG SIGNALS/BEHAVIOUR DURING EVENT	Page 17
14	PRACTICES & QUALIFYING	Page 18
15	QUALIFICATION	Page 19
16	MACHINES ENTERED IN TWO RACES	Page 20
17	CHANGE OF NUMBER	Page 20
18	CHANGE OF RIDER	Page 20
19	RACE PROCEDURE	Page 20
20	PROTESTS	Page 23
21	DRUG AND ALCOHOL TESTING	Page 23
22	WINNERS ENCLOSURE	Page 23
23	GARLANDING CEREMONY	Page 24
24	AWARDS	Page 24
25	TT PRIVATEERS CUP	Page 26
26	PRIZE PRESENTATIONS	Page 26
27	TRANSPONDERS AND AUTOMATIC TIMING	Page 27
28	ON BOARD CAMERAS AND GLOBAL POSITIONING SYSTEMS	Page 27
29	MOBILE PHONES	Page 27
30	VEHICLE RECOVERY SERVICE	Page 27
31	STEWARDS OF THE MEETING	Page 27
32	ACCEPTANCE OF RECORDS	Page 27
33	JURISDICTION	Page 27
34	PUBLICITY	Page 28
35	MERCHANDISING	Page 28
36	MISCELLANEOUS	Page 28

PRIZE MONEY

Page 29 - 32

APPENDIX

Page 32 - 41

I. ANNOUNCEMENT

ACU Events Limited ("the organisers"), a Company incorporated in Great Britain (Number 5781002) whose Registered Office is at ACU House, Wood Street, Rugby, Warwickshire, CV21 2YX, England, will organise the Isle of Man TT Races from the 29th May to 11th June 2010.

The Department of Tourism and Leisure ("the promoters"), an Isle of Man Government Department, whose Registered Office is St Andrews House, Finch Road, Douglas, Isle of Man, IM1 2PX, are the commercial rights owners of the Isle of Man TT Races and associated trademarks.

- ACU Permit Number: ACU 27589
- FIM Classic Meeting Number: FIM TBC

The TT Races have been granted the status of Classic Event by the FIM Management Council in recognition of their major contribution to the development of the motorcycle and the establishment of the sport internationally.

The meeting will be held under the National Sporting Code of the ACU and its appendices, these Supplementary Regulations and any further instructions issued or official announcements made ("the Regulations"). Copies of the ACU Handbook, containing the ACU National Sporting Code and appendices, are obtainable from Auto Cycle Union Ltd, ACU House, Wood Street, Rugby, Warwickshire, CV21 2YX, England, and priced £8.00.

2. OFFICIALS

Stewards of the Meeting:

Chief Steward (Appointed by the ACU)	Don Ryder
Steward	Geoff Karran MBE
Steward	Martin Moore MBE

FMN Delegates

Delegates from MCUI and other FMN's

As appointed

Race Management Team

Race Director	James Parker
Clerk of the Course	Eddie Nelson
Safety Officer	Dr Paul King
Medical Director	Dr David Stevens MBE
Department of Tourism and Leisure Representative	Paul Phillips
Assistant / Judicial Clerk of the Course	Gary Thompson MBE BEM
Deputy Clerk of the Course (Operations)	Phil Taubman
Deputy Clerk of the Course (Paddock / Start / Finish)	Peter Cain
Chief Technical Officer	Willy Clucas
Technical Director	Colin Hurst
Chief Timekeeper	Kevin Brookes
Chief Medical Officer	Heike Romer
Chief Incident Officer	Allan Killip MBE / Ned Bowers
Chief Press Officer	Simon Crellin
Rider Liaison Officers	John Barton / Richard Quayle
Secretary of the Meeting	Emma Connop

Address for all correspondence:

Secretary of the Meeting, Emma Connop, ACU Events Ltd, ACU House, Wood Street, Rugby, Warks, CV21 2YX

Tel: 01788 566413
Fax: 01788 573585
E-mail: emma.connop@acu.org.uk

3. COURSE

The meeting will be held on the Isle of Man TT Mountain Circuit which is 60.70km (37.73 miles) in length, on highway which is closed to the public during practice and race periods. ACU Course Licence no TT001

4. PROGRAMME OF RACES

Saturday 5th June

12:00 hrs	TT Superbike Race	6 laps
15:00 hrs	Sidecar TT Race 1	3 laps

Monday 7th June

10:45 hrs	Supersport TT Race 1	4 laps
14:15hrs	Superstock TT Race	4 laps

Wednesday 9th June

10:45 hrs	Supersport TT Race 2	4 laps
13:15 hrs	Sidecar TT Race 2	3 laps

Friday 11th June

12:30 hrs	Senior TT Race	6 laps
-----------	----------------	--------

5. ELIGIBILITY

a) Riders and Passengers

All Competitors resident in the UK must have held as a minimum a National Licence issued by the ACU or the SACU for at least twelve months prior to the closing date for entries. Passengers must hold a National Passenger Licence. Competitors from other FMN's must have held an FIM International Non - Championship Licence for a minimum of twelve months prior to the closing date for entries.

All competitors must be over 18 years of age on the 29th May 2010.

In addition to enter this event all competitors must hold a "TT Course Licence" issued by the ACU at a cost of £25.00 in addition to any normal licence fees. An application form for such a licence is enclosed with these Supplementary Regulations.

b) Entrants

Entrants must be in possession of a valid National Entrants or FIM Sponsors Licence for Road Racing.

c) Sidecar Passengers

Any competitor who wishes to be nominated as, or replace, a passenger, must hold a TT Course Licence (see 5 (a) above) as a passenger.

d) Machines

All motorcycles must comply with Appendix D of the ACU National Sporting Code Group A1 for solos and Group B2 for sidecars and with these TT Supplementary Regulations. The onus of ensuring the eligibility of any machine rests solely with the competitor. All Superbike, Superstock and Supersport machines must be on the 2010 FIM list of homologated motorcycles.

- TT Superbike Race

For machines complying with 2010 FIM Superbike regulations with the amendments specified in Appendix A of these TT regulations.

Over 750cc up to 1000cc	4 cylinders	4 stroke
Over 750cc up to 1000cc	3 cylinders	4 stroke
Over 750cc up to 1200cc	2 cylinder	4 stroke

- **Sidecar TT Races**

For machines complying with Formula Two Sidecar regulations as specified in Appendix B of these TT regulations.

- **TT Superstock Race**

For machines complying with 2010 FIM Superstock regulations with the amendments specified in Appendix D of these TT regulations.

Over 600cc up to 1000cc	4 cylinders	4 stroke
Over 750cc up to 1000cc	3 cylinders	4 stroke
Over 850cc up to 1200cc	2 cylinders	4 stroke

- **Supersport TT Races**

For machines complying with 2010 FIM Supersport regulations with the amendments specified in Appendix C of these TT regulations.

Over 400cc up to 600cc	4 cylinders	4 stroke
Over 600cc up to 675cc	3 cylinders	4 stroke
Over 600cc up to 750cc	2 cylinders	4 stroke

- **Senior TT Race**

For machines complying with the following specifications:

- TT Superbike
- TT Superstock (without limitation of tyre choice).
- Other machines admitted at the discretion of the organisers.

Competitors must enter the Senior TT on the Entry Form, but the organisers reserve the right to invite, or to accept applications from, other competitors to take part based on performances during the meeting. Such applications must be made no later than 1700 hrs on Tuesday 8th June.

Riders may be permitted (on application to the Clerk of the Course) to change machine to any other eligible machine on which the rider has qualified to race or has raced during the meeting (subject to paragraph f) below).

- **e) Personal Equipment**

While practicing and racing, riders and passengers are required to wear an identification disc attached around the neck by a material approved by the Technical Official. Thin chains should be avoided. The disc must be permanently marked with the wearer's full name and date of birth. Identification discs shall be of a durable material between 20mm and 25mm in diameter and having rounded edges with no sharp or ragged projections. The use of Kevlar suits by sidecar passengers is not permitted.

- **f) Multiple Races**

It is not permitted to ride the same motorcycle in more than one race held on the same day if this would result in the machine completing more than seven laps on that day.

6. ENTRIES

Applications for TT Race entries must be made on the official entry form and returned not later than Friday 26th February 2010

All completed entry forms should be returned to:

Secretary of the Meeting, Emma Connop, ACU Events Ltd, ACU House, Wood Street, Rugby, Warks, CV21 2YX
Tel: 01788 566413, Fax: 01788 573585, E-mail: emma.connop@acu.org.uk

Any entries received after the closing date will not be considered.

An entry may also be made by fax or by any other electronic means of communication provided the entry is received not later than the closing date. For the purpose of completing an entry form the entrant's signature may be an original written signature, a fax of the signature, or, in the case of web-based electronic submission of entry (primarily by the use of an internet entry form), the organisers may accept that the entry form has been duly signed if the entrant has positively agreed to be bound by the regulations.

Entries will be accepted in the following order of priority:-

1. Riders who finished in positions 1st to 30th in the corresponding race in 2009
2. Up to 30 additional riders in each race, based on previous fastest race lap speeds
3. Up to 20 newcomers in each race
4. Additional riders selected at the discretion of the organisers subject to a maximum of 80 starting entries in total in each race

Reserve Entries

For each solo race reserve entries may be accepted in addition to the maximum of 80 confirmed entries. Reserves will practice with confirmed entries. Subject to qualification they will take the places (but not necessarily the starting numbers) of confirmed non starters up to a maximum of 80 starters per race. New numbers will be allocated to reserves when they are guaranteed a start, at the discretion of the Race Management Team.

The promoters will continue to cover all entry fees (including Insurance), necessary to enter the 2010 Isle of Man TT Races.

Applicants will be advised as soon as possible after the closing date of entries, whether or not they have been accepted.

Entry forms not completed in full will be returned to the applicant.

The organisers reserve the right to refuse any entry.

7. TRAVELLING ALLOWANCE AND APPEARANCE FEES

Whilst no concessions for competitors are currently available directly from any travel companies accessing the Isle of Man, promoters will offer a travelling allowance to all competitors travelling to the Island.

This allowance is tiered depending on the origin of each solo rider and sidecar driver and the estimated cost of travel. This allowance will be available to any competitor who has commenced practice.

The allowance will be paid in GBP and will only be available by electronic payment direct to a bank account of the riders and drivers choosing.

All competitors qualifying for an allowance must include their bank details on the entry form. No payments will be issued using any other means.

This allowance is only available to competitors competing in the TT Races on the Mountain Circuit.

The travel allowance is tiered as follows –

- | | |
|-------------------------|------|
| • UK Mainland Solo | £500 |
| • UK Mainland Sidecar | £600 |
| • Rest of World Solo | £600 |
| • Rest of World Sidecar | £700 |

Any competitor wishing to apply for additional appearance fees should do so in writing providing information and justification to support the application to the promoters at:

TT Festival and Motorsport Arrangement Group, Willow House, Main Road, Onchan, Douglas, Isle of Man , IM3 1AJ
E-Mail: iomtt@gov.im

Requests must be in writing and must be made no later than the 26th of February 2010. Applications received after this date may not be considered.

Payments to riders and teams will be negotiated directly between the promoters and authorised representatives of the individual riders and teams.

The following items will provide the basis for the payment criteria –

- Potential media coverage value (team and / or rider) achievable before, during and after event
- Demonstrable ability to promote the TT and Isle of Man positively (team and / or rider)
- Previous performance at TT (team and / or rider)
- Previous recent performance at other high profile motorcycle international and domestic racing events (i.e. World Superbike Championship, British Superbike Championship , World Endurance Championship etc)
- Size and scale of team (infrastructure etc)
- Travel and other costs
- Number of races to be participated in

The above list is neither exhaustive nor absolutely definable and should only be used as a guide.

Any competitor receiving additional appearance support or riding for a team which is receiving additional appearance support does not qualify for the travel allowance payments.

Competitors receiving additional appearance support will not be paid without the submission of an invoice which can be submitted on or after the 30th June 2010 and all payments will be subject to the normal Isle of Man Government payment terms.

Provided that the services are deemed by the promoter in its absolute discretion to have been fully or substantially performed payment shall be made within 30 days of receipt of the said invoice.

Full or substantial performance shall require not less than the team and / or rider(s) having made a definite and legitimate effort to perform the services.

8. PADDOCK

The paddock will be organised by the promoter and its appointed agent G4S (Isle of Man) Ltd.

The Paddock Manager for G4S (Isle of Man) Ltd will be Chris Heyes.

Tel 01624 649021
Fax 01624 649049
Mob 07624 495105

E-mail chris.heyes@im.g4s.com

Parking of all team vehicles will be under the control of the promoter and its appointed agent and all teams must respect the instructions received.

Space will be allocated by the promoter and its appointed agent based on the information submitted by competitors on their entry form. The paddock parking position will be made by the promoter and its appointed agent and the decision will be final. Teams and / or competitors will receive notification of their paddock parking position on arrival.

The Paddock will open at 9:00am on Monday 24th May 2010.

The Paddock will be segregated into various areas into which teams will be entitled to bring certain vehicles.

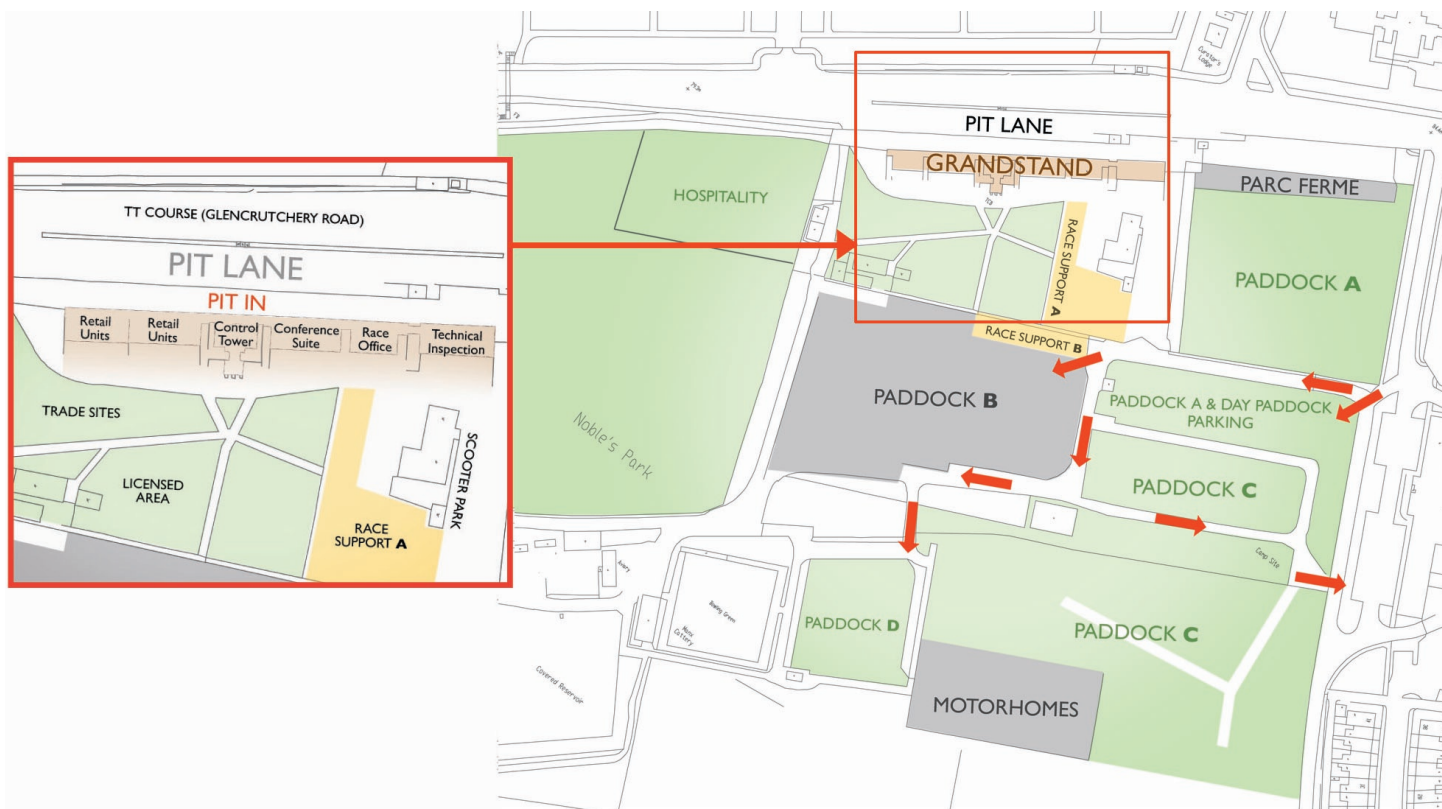

Paddock A

Paddock A will be reserved for the largest working trucks, i.e. those vehicles that carry the motor cycles and the equipment.

When semi-trailers are utilised, teams must be prepared to remove the tractor unit, if instructed, to a separate parking area.

No living vehicles will be allowed in Paddock A except where the living accommodation is an integral part of the working truck. Caravans with awnings will not be accepted as working vehicles.

Working vehicles must be painted in team or company livery. They must be well maintained and clean.

Any wastewater from the vehicles must discharge into a holding tank or, via a hose, to a drain. Any electric or other cables or hoses that cross roadways must be covered by a proprietary cable/hose protector.

Every team based in Paddock A must have a recognisable and presentable team uniform. The team uniform must be worn by all team members who work in Paddock A, Parc Ferme, Pit Lane or the Starting Grid during practice and racing.

Riders of any team in Paddock A will take part in the Paddock Walkabout on Saturday 5th June wearing their team uniform. Riders must be in position by 9:55am and will be expected to remain at their awning to sign autographs for up to one hour.

All teams in Paddock A must provide promotional posters or autograph cards for their riders to sign.

Paddock B

Paddock B will be reserved for medium and small working trucks, i.e. those vehicles that carry the motor cycles and the equipment and respective living quarters and separate riders living vehicles.

Any wastewater from the vehicles must discharge into a holding tank or, via a hose, to a drain. Any electric or other cables or hoses that cross roadways must be covered by a proprietary cable/hose protector.

Paddock C

Paddock C will be reserved for medium and small working trucks, i.e. those vehicles that carry the motor cycles and the equipment and respective living quarters and separate riders living vehicles.

Any wastewater from the vehicles must discharge into a holding tank or, via a hose, to a drain. Any electric or other cables or hoses that cross roadways must be covered by a proprietary cable/hose protector.

Paddock D

Paddock D will be reserved for the smallest trucks, vans, caravans and camping.

Any wastewater from the vehicles must discharge into a holding tank or, via a hose, to a drain. Any electric or other cables or hoses that cross roadways must be covered by a proprietary cable/hose protector.

Race Support Area A

The Race Support Area A is reserved for larger vehicles belonging to race support companies who provide a genuine service to competitors.

Companies supplying tyres to competitors are the only service companies entitled to erect working awnings.

Companies providing other services are restricted to the use of one working vehicle. Additional vehicles will be permitted at the discretion of the promoter and its appointed agent. A small awning may be used on these vehicles at the discretion of the promoters and its appointed agent where space permits.

Absolutely no hospitality must be provided by service company vehicles.

Race Support Area B

The Race Support Area B is reserved for smaller vehicles belonging to race support companies who provide a genuine service to competitors.

Companies providing services are restricted to the use of one working vehicle. Additional vehicles will be permitted at the discretion of the promoter and its appointed agent. A small awning may be used on these vehicles at the discretion of the promoter and its appointed agent where space permits.

Absolutely no hospitality must be provided by service company vehicles.

Retailing

Teams and competitors are not permitted to retail any goods or services from the paddock area during the TT period including merchandise. Any team or competitor wishing to retail in the specific paddock trade area should contact Motorsport Promotions Ltd on 01624667808.

Private Cars

Private cars are not permitted into any area of the Paddock other than the Team and Competitors Car Park. The vehicles must display a Team and Competitors Car Park vehicle pass to gain access to this area.

Containers

Containers will not be allowed in the paddock.

Scooters

Scooters can be used for paddock transportation by riders and team personnel only (not children). A designated, secure scooter park will be available adjacent to Paddock A.

Health and Safety

All competitors and their associated persons must at all times comply with all the health and safety requirements applicable in the paddock and displayed on the Race Office notice board.

Fuel Storage

There will be a dedicated high octane fuel storage facility within the paddock. Teams and competitors using high octane fuel must contact the Paddock Manager for further information before sending any fuel to the Island.

Teams and competitors using pump fuel are strongly advised to obtain fuel on the day it is to be used. Under no circumstance is more than 10 litres of fuel to be stored within any paddock (other than the official store). Teams and competitors who are storing fuels off site, are reminded of their obligations to let the authorities on the Isle of Man know what fuel is being stored and where.

It is the responsibility of all teams and competitors to remove all metal fuel containers to the skips provided in the paddock.

Any off site fuel storage facility (more than 2 litres) will need to be licensed by the Isle of Man Office of Fair Trading.

Please be aware that persons transporting large amounts of fuel may face prosecution if not appropriately licensed.

Competitors should consider how and when fuel is obtained for each qualifying session and race. Competitors using pump fuel are reminded that they should purchase the amount needed for that session or race and that they should not store more than is needed.

Fire Extinguishers

All competitors / race support / trade personnel using the paddock will need to supply a fire extinguisher. The extinguisher must be visible at all times and have an in date certificate attached. Checks will be made during the event. All team members must be aware of its location and have knowledge in how it is operated.

Fire Points

Fire points are located within Paddocks A, B, C and D and all team members must be familiar with their location. All Fire points are alarmed and extinguishers should not be removed unless needed in an emergency.

Welding / Welders

The use of welding equipment within the paddock area is strictly forbidden. Under no circumstance should teams or competitors bring welding equipment in to the paddock or associated areas. Any equipment found may be confiscated.

Generators

Generators must be placed in a safe working area. All cables used from generators or the electrical supply, must be covered by proprietary cable protector at all times. The use of generators should be kept to a minimum during night time hours.

Electrical Supply

Under no circumstance should anyone interfere with the electric supply from the power masters in the paddock. If an electric supply fails, please contact the Paddock Manager in the first instance.

Teams and competitors are required to have all electrical equipment PAT tested prior to use.

Security

The paddock will be covered by security guards. There are two, 24 / 7 security points which are fixed. There will be a foot patrol during daylight hours but no foot patrols between 1900hrs and 0700hrs.

Rubbish Removal

All competitors and team members are responsible for the removal of rubbish from parking and camping areas. Bins are provided for the disposal of bin bags located to the south of Paddock B.

Shower Block and Toilet areas

Showers and Toilet areas will be cleaned between the hours of 0700hrs to 2100hrs. All areas will be checked and cleaned every hour.

General Notice

A one way system will operate within the paddock. It has been designed for the smooth and safe transition of all vehicle movements. A 10 mph speed limit exists at all times. At no time should any vehicle block an entrance or exit.

9. PERSONNEL PASSES

There are different types of personnel passes depending on the activity of the pass holder:

Official Pass	(Red)
Promoter Pass	(Black)
Pit Team Pass	(Yellow)
Team Pass	(Blue)
VIP Guest Pass	(Green)
Guest Pass	(Orange)
Event Support	(White)

Official Pass (Red)

The Official Pass is issued to the personnel who operate in roles on behalf of the race organisers and promoters and will require access to all areas.

Promoter Pass (Black)

The Promoter Pass is issued to the personnel who operate in roles on behalf of the promoters and will have access to all areas except Pit Lane.

Pit Team Pass (Yellow)

The Pit Team Pass is issued to the personnel who work or do a professional activity during the event inside the restricted areas (Parc Ferme, Winners Enclosure, Start Line and including the Pit Lane).

Under no circumstances should Pit Team Passes be allocated or distributed to guests and any such passes will be withdrawn. Each solo rider and sidecar driver will be allocated a maximum of three Pit Team Passes. One additional Pit Team Pass for Team Managers may be allocated upon application to the Clerk of the Course.

Fire retardant overalls must be worn by all personnel in Pit Lane and this rule will be strictly enforced.

Team Pass (Blue)

The Team Pass is issued to the personnel who work or carry out a professional activity during the event inside the restricted areas (Parc Ferme, Winners Enclosure Start Line) but not the Pit Lane. Under no circumstances should Team Passes be allocated or distributed to guests and any such passes will be withdrawn.

VIP Guest Pass (Green)

The VIP Guest Pass is issued by the promoters and provides access to the Official Isle of Man TT Hospitality facility. Additional access to restricted areas (Parc Ferme, Start Line) will be granted by the promoter and such access will be marked on the pass. There will be four VIP Guest Passes, one for each race day, and will only be valid for the race day identified on the pass. This pass does not allow access to the Winners Enclosure or Pit Lane.

Guest Pass (Orange)

The Guest Pass is issued by the organisers and/or promoters and provides access to restricted areas Parc Ferme and Start Line. This pass does not allow access to the Winners Enclosure or Pit Lane.

Event Support Pass (White)

The Event Pass is issued to the personnel who work or carry out a professional activity during the event inside the restricted areas who are not race officials. This includes but is not restricted to personnel carrying out maintenance contractor work, cleaning and hospitality.

Pass General Rules

Teams and competitors are responsible for the integrity of the pass system within their team. Sanctions will be imposed on any team whose members abuse the pass system in any way including:

- Selling passes
- Production, sale or distribution of forged passes

Teams and competitors are also responsible for the behaviour of their guests. Guests should be advised that they are expected to respect the instructions of race officials.

By accepting the issue of passes for the 2010 Isle of Man TT Races, the team and / or competitor are deemed to agree to abide by the pass conditions and to undertake the obligation to advise each person to whom a pass is issued of the pass conditions and to ensure the observance thereof.

Passes may only be used to gain access to the areas indicated on the face of it. Any person found within a restricted area without the appropriate pass may be removed from the venue immediately and / or have any pass held by them withdrawn.

Isle of Man TT 2010 passes must not be removed from their official lanyards and must be worn around the neck of the person to whom it is issued so as to remain clearly visible at all times.

The organisers at all times reserves the right to refuse admission to the venue or access to a designated area to any person, notwithstanding that such person may have been issued with an appropriate pass.

Teams and competitors must keep accurate records of the numbers of passes that they issue to guests, this information must be available for audit by the organisers at an event.

The organisers reserve the right to request further proof of identity in addition to a pass.

2010 Isle of Man TT Races issued passes at all times remain the property of the organisers and may be issued, altered or withdrawn at any time at the absolute discretion of the organisers.

Team and competitor pass allocation will depend on the number of classes entered by the rider(s). The passes will be sequentially numbered and referenced for official use and riders and teams will be required to identify their teams pass holders on their entry form to allow the organisers to allocate individual passes to individual persons. Allocation will be worked out per rider based on the classes entered as follows –

<i>Classes</i>	<i>Pit Team</i>	<i>Team</i>
Superbike	3	2
Superbike / Snior / Superstock	3	3
Superbike / Senior / Superstock / Supersport	3	4
Supersport	3	2
Sidecar	3	4

Riders and teams wishing to request additional passes may do so in writing stating the reason for the request, number of passes required and names of the individuals those passes are to be assigned to. These requests will be considered by organisers.

10. INSURANCE

Competitors holding licences issued by a FMN other than the ACU or SACU must submit with the Entry Form (or send to the TT Race Office not later than Friday 30th April 2010) a Starting Permission countersigned and stamped by the FMN which issued their licence. This must confirm that, during the meeting and the official practice, they are insured against the risk of Personal Accident in accordance with the FIM Sporting Code but with additional cover for Medical Treatment and Repatriation costs, as follows:-

- \$35,000 (US Dollars) - Death
- \$70,000 (US Dollars) - Temporary Partial Disablement
- \$250,000 (US Dollars) - Medical Treatment
- \$100,000 (US Dollars) - Repatriation costs

For ACU and SACU licence holders, the organisers will arrange Personal Accident cover for the following benefits:

- £10,000 GBP Death or permanent total disablement
- £20,000 GBP Loss of or loss of the use of, one or more limbs or eye

Reciprocal Health Agreement

The Isle of Man Health Service is not part of the UK NHS and, except for immediately necessary and emergency treatment which does not require admission to hospital, visitors to the Isle of Man (including UK residents) who require treatment will be expected to pay for it.

ACU and SACU competitors are only covered by the ACU Insurance Policy for treatment required as the result of injuries sustained in an accident during Official practice, qualifying or racing on the TT Mountain Course.

It is therefore strongly recommended that all visitors to the Isle of Man ensure that they have appropriate insurance in place which will cover any treatment costs and repatriation to the UK by air ambulance if that should prove necessary.

This new situation applies to the competitor and every member of his team and family. This insurance can be obtained from Lockton International details below.

Note At the time of writing these new Insurance requirements are still liable to change and clarification and further details may be published by way of Bulletins and Final Instructions.

Increased Insurance benefits can be arranged either in the Race Office at the Grandstand (during the TT fortnight) or by application to:

Lockton International, 19 Spring Gardens, Manchester, M2 1FB

Tel:	0044(0)161 828 3300
Fax:	0044(0)161 828 3335
Web	www.locktonmotorsport.com
E-mail	dawn.luby@uk.lockton.com

10a Machines on the Public Highway

The law on the Isle of Man provides that no racing machines should be ridden on a public highway except during the period commencing 3 hours before, during and 2 hours after a scheduled road closure period from where the machine is kept, directly to the start of the course, from a point on The Course directly to the place it is kept, or between points on the course.

During this same period the machine does not have to comply with the Maintenance and Use and The Lighting Regulations.

The rider must however, have a current valid driving licence for that particular class of machine.

Third party insurance must be in force before the machine is used on a public highway. Cover can be obtained from the Race Office. Machines used on public roads, outside, these times must comply in every respect with Manx Road Traffic Legislation (Race numbers must not be displayed).

Any competitor reported as having ridden his/her machine in such a manner as to constitute a nuisance to the public may be disqualified or otherwise penalised.

11. SIGNING-ON / BRIEFING

a) **Signing-on**

All competitors must sign-on at TT Conference Centre, TT Grandstand, between the following times:

- Friday 28th May 1300hrs - 1630hrs
- Saturday 29th May 1000hrs - 1200hrs

All transponders, helmets, leathers, boots, gloves and identity tags must also be produced for inspection / approval.

A declaration must be signed by each competitor, regarding any injury / illness sustained since the issue of their current International licence. This declaration will also confirm that the competitor is fully acquainted with all regulations and instructions issued.

b) **Competitors Briefings**

All competitors must attend a briefing prior to being permitted to commence practice, this is compulsory. There will be separate briefings for Solo and Sidecar competitors. The briefings will take place in the Conference Centre adjacent to the Race Office at the following times:

Solos Only

- Friday 28th May 1700hrs
- Saturday 29th May 1000hrs French Speakers
- Saturday 29th May 1130hrs Newcomers.
- Saturday 29th May 1430hrs
- Monday 31st June 1500hrs

Sidecars Only

- Friday 28th May 1800hrs
- Saturday 29th May 1000hrs French Speakers
- Saturday 29th May 1330hrs including Newcomers
- Saturday 29th May 1530hrs
- Monday 31st June 1600hrs

All Solo newcomers must attend the briefing on Saturday 29th May at 1130hrs. Following this briefing, newcomers will be taken on a tour of the circuit with an experienced instructor; For all Sidecar newcomers there will be a similar tour following the briefing at 1330hrs. All Newcomers must arrive and sign-on in time to attend the briefing on Saturday and must join the tour following such briefing or they may be disqualified. All newcomers must take part in the speed controlled lap on Saturday 29th May. Applications for a dispensation to the above rule must be made in writing to the Clerk of the Course by 1000hrs on 29th May 2010.

c) **Technical Briefings**

A technical briefing for team managers plus one mechanic per competitor will be held in the Conference Centre adjacent to the Race Office at the following times:-

- 0900hrs Sunday 30th May for Solos
- 1030hrs Sunday 30th May for Sidecars

It is important that each competitor is represented at this briefing.

12. TECHNICAL INSPECTIONS

a) Number plates

- Superbike TT White plates with black numbers
- Sidecar TT Red plates with white numbers
- Superstock TT Red plates with white numbers
- Supersport TT White plates with blue numbers
- Senior TT For machines entered only in the Senior TT – yellow plates with black numbers
For all others - plates and numbers of the colours appropriate to the class of the motorcycle

The following colours must be used following the RAL colour table:

- Black 9005
- Blue 5010
- Yellow 1003
- Red 3020
- White 9010
- Green 6002

All number plates and numbers must be supplied by competitors.

- Each machine must display one front and two side number plates for practice and races, so that both front and side numbers are clearly visible to the public and marshals on both sides of the road and must comply with the following regulations:
- Front Numbers must be fitted directly on the front of the fairing not on a side. All fairings must be modified to accommodate this. Where the design of the fairing makes this impossible the numbers must be affixed to both sides
- The figures must be clearly legible and like the background must be painted in colours to avoid reflection from sunlight. The minimum dimensions of the figures are as follows:-

Height of figure		Width of figure		Width of stroke	Space between 2 figures
Front	160mm	Front	80mm	25mm	15mm
Side	120mm	Side	60mm		

Each machine must display an ACU decal in a prominent position on the machine during practice and racing. The decal will be supplied by the organisers.

In the case of any dispute concerning the legibility of numbers the decision of the Chief Technical Officer will be final. In case of difficulty in the identification of a machine the organisers also reserve the right to require any competitor to use officially supplied numbers.

b) Pre-Practice and Qualifying Technical Inspections

All machines bearing the correct number plates and transponders must pass through the Technical Inspection bay for inspection / approval prior to each practice or qualifying session, during the times listed. Machines will not be approved if their appearance is not appropriate to the status of the event. Riders shall remove fairings from their machines if required by the Chief Technical Officer

Saturday 29th May

Solos	1600 hrs - 1930 hrs
Sidecars Newcomers	1730 hrs - 1800 hrs
Sidecars	1800 hrs - 2025 hrs

Monday 31st May

Solos	1600 hrs - 1930 hrs
Sidecars	1800 hrs - 2025 hrs

Tuesday 1st June

Solos	1600 hrs - 1930 hrs
Sidecars	1800 hrs - 2025 hrs

Wednesday 2nd June

Solos	1600 hrs - 1930 hrs
Sidecars	1800 hrs - 2025 hrs

Thursday 3rd June

Sidecars	1600 hrs - 1930 hrs
Solos	1800 hrs - 2025 hrs

c) Pre-Race Technical Inspections - Machines

All machines bearing the correct number plates and transponders must pass through the Technical Inspection bay for inspection / approval prior to each race, during the times listed. Machines will not be approved if their appearance is not appropriate to the status of the event. Riders shall remove fairings from their machines if required by the Chief Technical Officer

Competitors must ensure that their machines are presented at the times listed:

Saturday 5th June

Superbike TT Race

Nos 60 upwards	0845 hrs – 0915 hrs
Nos 30 – 59	0915 hrs – 0945 hrs
Nos 1 – 29	0945 hrs – 1015 hrs

Sidecar TT Race 1

Nos 60 upwards	1115 hrs – 1145 hrs
Nos 40 – 59	1145 hrs – 1215 hrs
Nos 20 – 39	1215 hrs – 1245 hrs
Nos 1 – 19	1245 hrs – 1315 hrs

Monday 7th June

Supersport TT Race 1

Nos 60 upwards	0830 hrs – 0900 hrs
Nos 30 – 59	0900 hrs – 0930 hrs
Nos 1 – 29	0930 hrs – 1000 hrs

Superstock TT Race

Nos 60 upwards	1230 hrs – 1300 hrs
Nos 30 – 59	1300 hrs – 1330 hrs
Nos 1 – 29	1330 hrs – 1400 hrs

Friday 4th June

Solos	1600 hrs - 1930 hrs
Sidecars	1800 hrs - 2025 hrs

Saturday 5th June

Superstock TT and Supersport TT	1445 hrs - 1615 hrs
---------------------------------	---------------------

Monday 7th June

Sidecars	1000 hrs – 1130 hrs
----------	---------------------

Wednesday 9th June

Senior TT	1245 hrs - 1415 hrs
-----------	---------------------

Wednesday 9th June

Supersport TT Race 2

Nos 60 upwards	0830 hrs – 0900 hrs
Nos 30 – 59	0900 hrs – 0930 hrs
Nos 1 -29	0930 hrs – 1000 hrs

Sidecar TT Race 2

Nos 60 upwards	1030 hrs – 1100 hrs
Nos 40 – 59	1100 hrs – 1130 hrs
Nos 20 – 39	1130 hrs – 1200 hrs
Nos 1 – 19	1200 hrs – 1230 hrs

Friday 11th June

Senior TT Race

Nos 60 upwards	1000 hrs – 1030 hrs
Nos 30 – 59	1030 hrs – 1100 hrs
Nos 1 – 29	1100 hrs – 1130 hrs

Applications for time extensions from the allotted pre-race examination time must be addressed to the Chief Technical Officer, in writing, prior to the allotted official pre-race examination time.

Machines must be ready to race, with fuel added.

After pre-race examination machines must immediately be placed in the Parc Ferme. Tyre warmers may then be fitted and all personnel then immediately leave the Parc Ferme. No other work may be carried out on any machine until 45 minutes prior to the start of the race.

d) Verification of Machines

The organisers reserves the right to examine and require dynamometer checking and / or dismantling of any motorcycle that has started in any practice or race, and for this purpose, to impound it and retain it in official custody for as long as may be required. Fuel samples may be taken, fuel tanks measured and weights checked.

In the TT Superstock Race a dynamometer will be used to check power output (motorcycles must be submitted for these checks no later than noon on Wednesday 2nd June) and at least the first three machines, together with class winning machines plus up to three at random as selected by the Technical Steward will be required to undergo a post-race dynamometer check and may be dismantled for technical examination. Similar checks and dismantling may be required for machines entered in other races. Fuel samples will be taken, fuel tanks measured and weights checked.

Any necessary dismantling of a motorcycle shall be carried out by an accredited representative of the team and /or competitor under instructions of the Technical Control Official. Dismantling must be commenced as soon as the engine is cool enough. There will be no facility to seal engines for dismantling at a later date.

The organisers may also require any motorcycle to be dismantled, examined and retained for as long as is deemed necessary following an incident, in either practice or races. Helmets and clothing must also be presented for re-inspection subsequent to any incident.

All costs relating to the verification of machines are to be met by the team or competitor.

Any competitor wishing to claim lap money, or an award must make his machine available for post race verification.

Any competing motorcycle or equipment left unattended, on or adjacent to the circuit, after taking part in a practice or race may be taken charge of by the organisers. The organisers accept no responsibility for any such motorcycle or equipment.

e) Change of Motorcycle

An entrant wishing to change the make or type of motorcycle, after entries have closed must apply to the organisers, prior to the meeting and during the meeting to the Race Office for approval by the Clerk of the Course. The competitor must qualify on the make, type and capacity of the machine to be raced.

f) Fuel

Fuel for all practices and races must comply with the ACU Specification as follows:

Normal unleaded fuel, with a maximum lead content of 0.005 g/l (unleaded) and a maximum MON number of 90 (The Control

Fuel for the British Superbike Championship meets with these specifications).

These regulations strictly prohibit the use of 'Bluegas', power boosters, octane boosters and the like. No additions are allowed to the fuel with the exception of water or standard lubricants sold to the public.

It is the competitors responsibility to provide fuel for practice and races. No fuel will be available to purchase in the paddock. It is also the competitors responsibility to ensure that his/her allocated filler, which will be provided, operates correctly. Any fuel left in fillers will be drained and removed, however it is the competitors responsibility to check that his filler has been drained prior to adding his own fuel. The use of other quick-filling equipment will not be allowed.

The Steam Packet Company has stated that fuel may only be carried in the tanks of machines; cans / barrels will not be allowed. Spot checks will be carried out and anyone found in contravention of this ruling will not be permitted passage to the Island.

Anyone wishing to import fuel into the Isle of Man must contact:

Trading Standards Division
Office of Fair Trading
Lord St
Douglas
Isle of Man
IMI ILE

Tel: +44 (0)1624 686520
Fax: +44 (0)1624 686709

In practice or races, no fuel shall be carried on the motorcycle or by the rider or passenger otherwise than in a tank, securely fitted to the motorcycle for the purpose. For solo machines one tank only is permitted. For sidecars two interconnected tanks are permitted.

The organisers reserve the right at any time to take samples of the fuels used.

g) Fuel Tanks /Capacities

In the interest of safety, the use of ready fuelled replacement tanks in the pit will not be permitted. Replacement tanks are permitted but must be empty and may only be filled when securely attached to the machine. Refuelling during the progress of any race must be carried out at the competitors designated pit. It is forbidden to open tank filler caps until the machine is stationary at its allotted pit and the engine is switched off. Penalty may be disqualification. The use of temporary filling material to reduce the capacity of the tank is forbidden, and any material placed in fuel tanks will not be taken into account when tanks are measured.

Superbike TT Race and Senior TT Race

It is permitted to modify the standard manufacturer's tank provided the silhouette of the tank remains as homologated. See Appendix A

Supersport TT Race

It is permitted to modify the standard manufacturer's tank provided the silhouette of the tank remains as homologated. See Appendix "C".

Superstock TT Race

It is permitted to modify the standard manufacturer's tank provided the silhouette of the tank remains as homologated. See Appendix "D".

The refuelling equipment supplied by the organisers must be used and must not be modified.

All filler nozzles will be to unleaded specification.

h) Oil Containment

On all four stroke solo machines the lower fairing has to be constructed to hold, in the case of an engine breakdown, at least half of the total oil and engine coolant capacity used in the engine (minimum 5 litres).

[For sidecars see Appendix B]

i) Metallic Material

The use of metallic material in any item of clothing or personal protection which regularly comes into contact with the track is prohibited (e.g. knee sliders, boots etc).

13. FLAG SIGNALS/BEHAVIOUR DURING EVENT

(a) The following flag signals will be used during Practice and Races and must be immediately obeyed by competitors:

Manx National Flag	Start
Yellow and Red striped flag	Oil, water or other substance is affecting adhesion on this section of the Track
White Flag with "SUN" or "S"	Sun dazzle warning
White Flag with 'V'	Bad visibility warning
White Flag	Slow moving car, ambulance or similar vehicle on track

Note: It is forbidden for a rider to overtake another rider during the display of the white flag. Overtaking the slow moving vehicle is permitted.

Black and White chequered flag	Finish of race or practice session
Yellow Flag (Stationary)	Danger; slow down, overtaking forbidden
Yellow Flag (Waved)	Danger; slow down, prepare to stop, overtaking forbidden
Green Flag	Course Clear
Red Flag	The practice or race is being interrupted, the Red Flag will be shown waved at each marshals post. Riders will be directed by the marshals.
Black Flag with Orange Disc displayed with rider's number	That competitor to stop immediately

Only authorised officials are permitted to use these flags and. No other flag or light signals of any kind are permitted. Only the Clerk of the Course or in his absence the Deputy Clerk of the Course can authorise a race to be stopped.

- (b) Riders must ride in a responsible manner which does not cause danger to other competitors or participants, either on the track or in the pit-lane. Riders must at all times adhere to the provisions of the Regulations.
 - (c) Riders should use only the track and the pit-lane. However, if a rider accidentally leaves the track then he may rejoin it at the place indicated by the marshals or at a place which does not provide an advantage to him. The marshals may assist the rider to the extent of helping him to lift the machine and holding it whilst any repairs or adjustments are made. Any repairs or adjustments must be made by the rider working alone with absolutely no outside assistance. The marshal may then assist him to re-start the machine.
 - (d) If the rider intends to retire then he must park his motorcycle in a safe area as indicated by the marshals.
 - (e) If the rider encounters a problem with the machine which will result in his retirement from the practice or the race, then he should not attempt to tour at reduced speed to the pits but should pull off the track and park his machine in a safe place as indicated by the marshals.
 - (f) Riders must not transport another person on their machine.
 - (g) Riders must not ride or push their motorcycles in the opposite direction of the circuit, either on the track or in the pit lane, unless doing so under the direction of an Official.
 - (h) No signal of any kind may pass between a moving motorcycle and anyone connected with the motorcycle's entrant or rider; save for the signal from the time keeping transponder; from on-board cameras, or messages on a pit board or body movements by the rider.
 - (i) Stopping on the track during practices and races is forbidden.
 - (j) A rider or passenger involved in an incident will not be allowed to continue practicing or racing until he has been passed medically fit by one of the event Medical Officers.
-

14. PRACTICES AND QUALIFYING

a) General

During any practice or qualifying period, the Clerk of the Course or his Deputy may decide to flag off riders between Governor's Bridge and the finishing line. In this case the foreshortened lap and the time recorded at the flagging off point will be counted towards qualification for the races.

Information regarding retirements during practice or qualification will be available from the Race Office.

b) Practice and Qualifying Periods

- Saturday 29th May

1820 hrs - 1835 hrs	Solo Newcomers' speed controlled lap
1825 hrs - 1840 hrs	Sidecar Newcomers' speed controlled lap
1845 hrs - 1955 hrs	Solo Free Practice
2005 hrs - 2050 hrs	Sidecar Free Practice

- Monday 31st May

1820 hrs - 1950 hrs	Solo Qualifying 1
2000 hrs - 2050 hrs	Sidecar Qualifying 1

- Tuesday 1st June

1820 hrs - 1950 hrs	Solo Qualifying 2
2000 hrs - 2050 hrs	Sidecar Qualifying 2

- Wednesday 2nd June

1820 hrs - 1950 hrs	Solo Qualifying 3
2000 hrs - 2050 hrs	Sidecar Qualifying 3

- Thursday 3rd June

1820 hrs - 1950 hrs	Sidecar Qualifying 4
2000 hrs - 2050 hrs	Solo Qualifying 4

- Friday 4th June

1820 hrs - 1950 hrs	Solo Qualifying 5
2000 hrs - 2050 hrs	Sidecar Qualifying 5

- Saturday 5th June

1640 hrs – 1740hrs	Superstock TT and Supersport TT additional Qualifying
--------------------	---

- Monday 7th June

1230 hrs – 1300 hrs	Sidecar additional Qualifying
---------------------	-------------------------------

- Wednesday 9th June

1505 hrs – 1535 hrs	Senior TT additional Qualifying
---------------------	---------------------------------

c) Orange Jackets

All newcomers are required to wear an orange jacket during practice. These must be collected from the Race Office during signing on. This does not apply to sidecar passengers.

d) Newcomers

For the purpose of these regulations a "Newcomer" is a person who has not previously taken part in a race on the TT Course or qualified to do so. A previous TT sidecar passenger will be regarded as a newcomer driver or solo rider. A previous TT solo rider will be regarded as a newcomer sidecar driver or passenger and a previous TT sidecar driver will be regarded as a newcomer solo rider.

e) Fire retardant overalls

These must be worn by all mechanics / assistants in the pit lane and the race organisers may carry out random inspections of fire retardant overalls being used in the pit lane area.

15. QUALIFICATION

To start a race, a newcomer to the TT Circuit, qualifying for the first time must complete a total of at least 6 laps on a solo machine or 4 laps on a sidecar machine. This applies to sidecar passengers as well as driver. Newcomers must have signed on, attended a briefing and a newcomers course tour on Saturday 29th May, and commenced qualifying including completion of a speed controlled lap by the end of Tuesday's qualifying session and should have completed 3 laps by the end of Wednesday's qualifying session, or they may be disqualified.

All competitors must have signed on and commenced qualifying by the end of Wednesday's session.

Competitors who have qualified to start in any previous race on the Mountain Circuit (TT or Manx Grand Prix) shall be required to complete a minimum of 5 laps for solos and 3 laps for sidecars, unless the Clerk of the Course grants permission otherwise.

For all Isle of Man TT Race classes a minimum of 2 laps must be completed on each machine entered, one of which must be within the qualifying criteria.

Any competitor who does not attain the required number of laps or qualification time may not be permitted into the race.

Free Practice on Saturday 29th May 2010 will be un-timed but laps will count towards qualifying laps.

All qualifying, including that on race days will be officially timed and count towards qualification.

Sidecar drivers must qualify with the passenger with whom they intend to race. In the event of a change of passenger the driver must re-qualify with the new passenger.

Qualification times

All Solo Classes: 115% of the time set by the third fastest qualifier in the class

Sidecar TT Races: 120% of the time set by the third fastest qualifying team in the class

These qualifying times will be based on the times set at the close of qualifying on Friday 4th June.

The qualification regulations will only be waived at the absolute discretion of the Race Management Team whose decision will be final.

16. MACHINES ENTERED IN TWO RACES

It is permitted to enter for TT Superbike and TT Superstock on the same machine provided that this machine meets the requirements of these regulations for both classes. A rider wishing to race one machine in two classes must indicate his / her intention to do so on the entry form and must then complete a separate declaration when signing on. Riders using the same machine in both classes will appear in the results of each practice for both classes (denoted by # in the Superstock practice results). During practice the rider having completed the declaration at signing on will be permitted to practice only on the number allocated to him/her for the TT Superbike class. In the races he will use the number allocated to him/her for that particular Race.

17. CHANGE OF NUMBER

The organisers reserve the right to re-allocate numbers on conclusion of qualifying.

Applications for changes of machines and / or riders deemed, by the organisers, to have as their object a change of number, will be refused.

All queries relating to number changes will be handled by the Rider Liaison Officers.

18. CHANGE OF RIDER

No application for a change of rider will be considered if an entry submitted by the substitute rider (or on his / her behalf by an entrant) for TT 2010 has already been refused.

A change of both rider and make of motorcycle may be permitted at the discretion of the Clerk of the Course.

19. RACE PROCEDURE

a) *Start Preliminaries*

First Signal - 45 minutes before start.

Competitors take possession of machines in assembly area. Engines may be started for warm up period. Petrol and oil tanks may be topped up and adjustments made.

Second Signal - 30 minutes before start.

Third Signal - 15 minutes before start.

Competitors marshalled to starting grid and lined up in order. Riders on the grid may at this stage make adjustments to the motorcycle or change tyres to suit the course conditions. Tyre warmers may be used on the grid, powered by a generator. Only one generator per machine may be used. The generator must be of the "hand carried" type and have a maximum output capacity of one kilowatt. The noise limit of the generator is 65 dB/A. No batteries or other electrical supplies are permitted on the grid except a self-contained starting device. All adjustments and changes of tyres/wheels must be completed by the fourth signal.

Fourth Signal - 5 minutes before start.

Clear grid on the Instructions of officials. Engines must be running. Exit gate from warm-up/assembly area to start line will close.

Riders will not start until the starting flag is dropped. Any rider who starts before the starting flag is dropped, or who fails to start immediately the starting flag is dropped, may be penalised.

A competitor, who is not in position to start within 10 seconds of the scheduled starting time, may only start 10 seconds after the last competitor is scheduled to start. His starting time may at the discretion of the Clerk of the Course be adjusted to coincide with the new starting position (normal interval times will be observed). Only during the start procedure is a competitor permitted to stop on the course adjacent to his pit. At all other times a competitor must use the pit access road and stop in front of his designated pit.

b) Start Procedure

All races will be clutch start. Competitors will be started singly at 10 second intervals.

In exceptional circumstances, the start of any race may be officially delayed, reduced in number of laps and if necessary, postponed until the following day or another designated day.

c) Pit Lane

i) Conditions

The TT Pits Lane is a Licensed Petroleum Storage Area under the Isle of Man "Dangerous Goods Act" and as such the following conditions apply:

- a) There must be NO SMOKING or naked lights. Engines must be stopped whilst the machine is being refuelled. Any electrical equipment used or taken within 14ft of refuelling equipment must be either intrinsically safe or flame proofed. This includes power tools, two-way radios, transistor radios, cameras etc. Spare batteries must be protected.
- b) Petrol cans used for filling and draining must be metal or BSI approved.
- c) Filling or refuelling of tanks must not commence before the Fire Service arrive and in any case not sooner than one hour before the scheduled race start time. It must be completed not later than thirty minutes before the start time. Fire retardant overalls must be worn when filling or refuelling tanks.
- d) When refuelling tanks are being filled or drained, only those persons immediately involved and race officials are permitted in the pit area.
- e) Refuelling tanks must be drained when the pit lane is closed towards the end of the race. Fire retardant overalls must be worn when draining tanks.
- f) When a competitor vacates his pit he must not carry unused fuel or empty drums that have contained fuel beneath the Grandstand.
- g) The refuelling equipment supplied by the organisers must be used and must not be modified. All filler nozzles will be to unleaded specification.

ii) Attendants

Each competitor is permitted up to three Attendants. Bona fide Team Managers who are representatives of licensed entrants and who are attending more than one rider will, on application to the Clerk of the Course, be given an additional pass to enable them to attend more than one pit in addition to the three Attendants working in each of those pits. Such Team Managers may not work on motorcycles or helmets or clothing or physically assist riders. Team Managers and Attendants must at all times obey official instructions. If a Team Manager or Attendant fails to obey such instructions or commits any breach of regulations; their competitor may be held responsible and penalised.

Team Managers and Attendants must wear fire retardant overalls and suitable footwear at all times in the pit lane. Footwear worn by Team Managers and Attendants must not have any studs, steel tips etc.

All Team Managers and Attendants must remain in the pit allotted to them, except when their competitor is at the pit, when Attendants may assist or carry out replacements and repairs, only using the spares previously deposited in the pit. Wheels fitted with tyres may be brought into the pit during a race.

One or two attendants may assist the competitor to re-start from the pit.

Self-contained remote starters for the TT Superbike and Senior TT races will be permitted, provided applications are made to the Clerk of the Course and approval given at least 24 hours before the scheduled start of the race. All such remote starters must be intrinsically safe and must be stored within the pit box. Remote starters must NOT be started until all refuelling and servicing is completed.

The use of purpose made front wheel paddock stands designed to elevate the front of the motorcycle during refuelling is permitted. The use of ramps or other means for this purpose is forbidden.

Smoking is strictly forbidden in the Technical Inspection Bay, Parc Ferme, Pit Lane, Pits and Start line areas.

Crossing of the pit lane is permitted only in the designated area at the start of the Pit Lane.

iii) Pit Stops during races

Pit Lane – Speed Limit – 60kph

At the entrance to the Pit Lane the Stop Box has been removed.

At the entrance to the Pit Lane there is a Single White Line with a board at each side indicating a speed limit of 60 kph. From this point until the Pit Lane Exit – which is indicated by a White Line with a board at each side with the 60kph crossed out, the speed limit is 60kph.

This speed limit will be policed by transponder loops in the Pit Lane.

Sanctions will be imposed on any competitor breaking the speed limit of 60 kph as follows:

- Over 60kph but not over 80kph - a time penalty of 30 seconds.
- Over 80kph but not over 100kph - a time penalty of 60 seconds
- Over 100kph - disqualification from the race.

In the event of more than one infringement during a single Pit Stop the highest penalty will be awarded.

These penalties will be a matter of fact with no right of protest or appeal.

At the entrance to the Pit Lane a display board will indicate the speed of competitors approaching the Pit Lane. This is only an indication to assist competitors.

d) Means of Propulsion

During a race a motorcycle can only be propelled by its own power; the muscular effort of its rider and/or its passenger and by the natural forces of gravity.

e) Finish of a race

Riders who have completed the designated number of laps for the race will be shown a chequered flag by an official standing at the finish line, at track level. Riders who cross the finish line without completing the designated number of laps but after the leading rider on the road has been shown the chequered flag will be permitted to proceed on a further lap but after a race has been won and where in the opinion of the Clerk of the Course it is no longer possible to qualify for a cash award or replica, he will order all competitors to stop as each crosses the finishing line, irrespective of the number of laps completed. Red lights will then be shown prior to the return road gate and a marshal showing a red flag will stand at the return road gate. To be counted as a finisher in the race and to be included in the race results a rider must complete the full designated number of laps for the race and cross the finish line within a time decided by the Clerk of the Course. The rider must be in contact with his/her machine.

f) Stopping a race

A race will not be stopped prematurely unless the Clerk of the Course deems it necessary, but if so stopped before the leading competitor has completed half of the total race distance, the race will be declared abandoned. Lap money may be paid on laps completed and any re-run race will be for the remaining lap prize money only. The finishing positions in an abandoned race will be ignored for the purpose of classification of the race result.

A race stopped after the leading competitor has completed half of the scheduled race distance will be deemed to have been completed and the prize money re-allocated by the organisers as they consider appropriate. The Clerk of the Course reserves the right to postpone or abandon any or all of the races if he considers it necessary.

The Clerk of the Course may, notwithstanding the previous paragraphs, declare a result of any race based on such assessment as he thinks appropriate and, in doing so, may apply Sections 10 and 12 of the ACU Standing Regulations for Road Racing to such extent (if any) as he thinks appropriate in the circumstances.

In the event of the Clerk of the Course stopping a race prematurely due to 'force majeure' circumstances, waved red flags will be displayed at various points on the Course on the instructions of the Clerk of the Course or his Deputy. Stationary yellow flags will be displayed at intermediate marshals' posts. In addition a suitable warning board will be displayed at Governors' Bridge indicating that all competitors will be stopped at the start/finish line by means of Red Flag and Red Lights. In the event of the Clerk of the Course shortening (as opposed to stopping) a race, this decision may be given to all riders at various points on the course. In these circumstances the chequered flag will be displayed at the start/finish line.

g) End of Race Procedure

At the conclusion of all races the finishers will be required to return their machines to the Parc Ferme. This will be located in the Assembly Area. They will be held for as long as required. (See also Para 12 (d))

20. PROTESTS

Protests must be in accordance with the ACU National Sporting Code Chapter 10, and accompanied by a fee of £100. In addition if the dismantling of an engine is involved, a deposit of £250 for a Four-stroke or £150 for a Two-stroke machine must be submitted with the Protest Fee. In the event of the protest being upheld the Deposit will be returned. If the protest is unsuccessful the deposit will be awarded to the winning party and will be the only cost claimable. The time limit for making a protest will be 30 minutes after the display of the provisional results on the Official Notice Board in the Race Office. The deposit for a fuel test will be £600.

21. DRUG AND ALCOHOL TESTING

Procedures will be as prescribed in the current ACU National Sporting Code.

22. WINNERS ENCLOSURE

At the conclusion of each race the first three finishers will be directed into the Winners Enclosure with their machines to conduct interviews with the host television and radio broadcasters. No other television or radio journalists will be permitted to operate in this area.

The Winners Enclosure will be separated into three distinct areas and certain passes will allow access to certain areas of the Enclosure. The centre of the enclosure will be the area the first three finishing machines will be parked. Only the competitors and their crew who have a pit team pass will be allowed in this area. No other pass holders will be permitted in this area. Outside of the main Enclosure will be two other areas. One will be clearly identified as a 'press pit' and will be for Gold and Silver Press Pass holders only. The remaining area will can be accessed by individuals with an Official Pass, Promoter Pass or Team Pass.

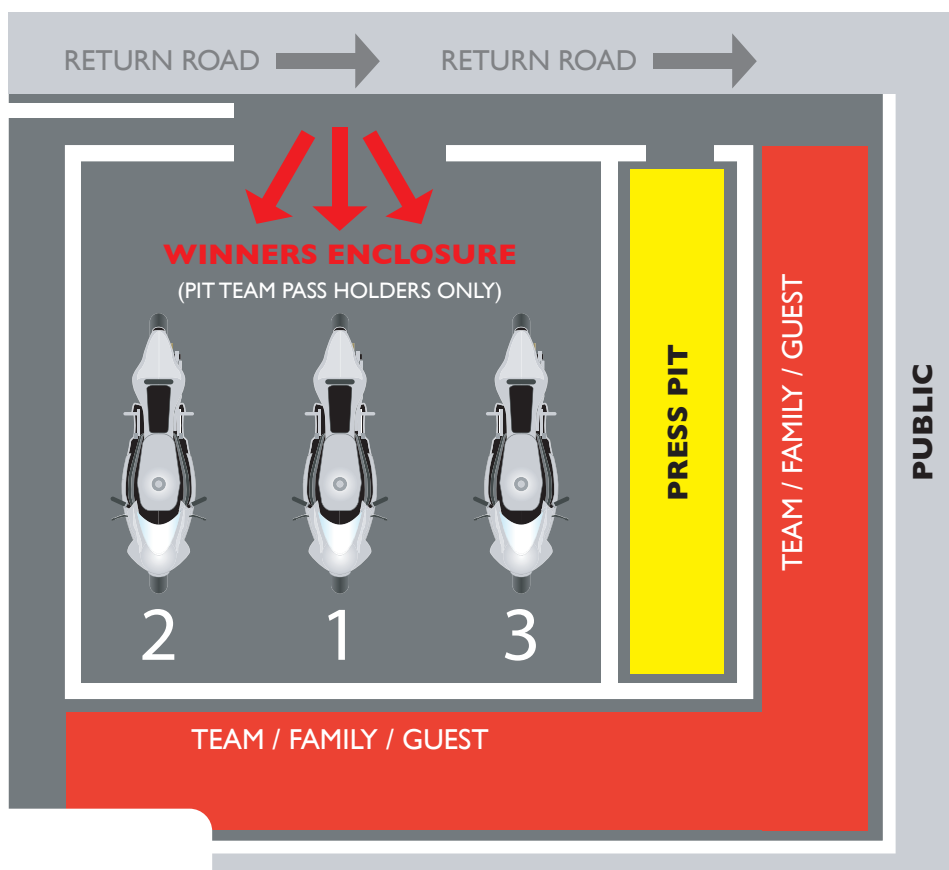

23. GARLANDING CEREMONY

Riders finishing first, second and third in each race will be required to take part in a short ceremony to be held in front of the Grandstand to acclaim and garland the winners.

24. AWARDS

All trophies will be retained by the organisers and the winners will receive an award which may be kept as a permanent memento.

- **Race Winners Trophies**

TT Superbike Race	TT Superbike Tourist Trophy
Sidecar TT Race 1	Fred W Dixon Trophy
TT Supersport Race 1	Junior Tourist Trophy
TT Superstock Race	John Hartle Trophy
TT Supersport Race 2	Classic TT Trophy
Sidecar TT Race 2	Sidecar Tourist Trophy
Senior TT Race	Senior Tourist Trophy

- **Fastest Lap Awards**

TT Superbike	John Williams Trophy
Sidecar TT (overall)	Jock Taylor Trophy
TT Superstock	Don Ryder Trophy
Supersport TT (overall)	TT Formula 2 Cup
Senior TT	Norman Brown Trophy
Fastest lap of the meeting	Jimmy Simpson Trophy

- **Special Awards**

- **Joey Dunlop TT Solo Championship Trophy**

To the overall TT Solo Champion decided using the accumulation of points from a World Championship points system for each solo race during the 2010 TT Festival plus £10,000.

- **RAC Sidecar Championship Trophy**

To the overall TT Champion across both sidecar races worked out on a World Championship points system plus £3,000.

- **TT Supporters' Club Trophy**

To the competitor with the fastest aggregate time in the TT Supersport Race 1 and Race 2.

- **Vernon Cooper Trophy**

To the solo newcomer with the highest placed finish in any solo race during the meeting.

- **Craig Trophy**

To the passenger of the winner of the RAC Trophy.

- **Fred Hanks Trophy**

To the Chassis Manufacturer with the fastest aggregate time in the two sidecar races.

- **Bill Boddice Trophy**

To the Sidecar Team with the fastest aggregate time in the two sidecar races.

- **Peter Chapman Trophy**

To the sidecar newcomer with the highest placed finish in any sidecar race during the meeting. Both members of the crew never having started or qualified to start in a sidecar race on the TT course prior to the meeting.

- **Joe Craig Trophy**

To a British competitor of a solo motorcycle of British manufacture who has made the best performance in any race as a percentage of the winner's time.

- **Martin Finnegan Trophy**

To the Irish solo competitor attaining the fastest overall lap speed during TT Race Week plus £1,000

- **Frank Cope Trophy**

To the Competitor in the meeting whose performance is adjudged to be the most meritorious having regard to the competitors seniority of age.

- **Gavin Lee Trophy**

To the Competitor, resident in the Isle of Man, with the best finish in the Senior TT Race.

- **Ice Man Trophy**

To the Competitor, permanently resident outside of the UK and Ireland whose performance is adjudged to be the most meritorious throughout the race period.

• **Silver Replicas**

Will be awarded to the riders finishing within 105% of the winner's time.

• **Bronze Replicas**

Will be awarded to the riders finishing within 110% of the winners time but not qualifying for a silver replica.

• **Finishers Medals**

Will be awarded to all other finishers.

• **Fastest Lap**

A silver replica will be awarded to the competitor making the fastest lap in each race.

• **Newcomers Medals**

The top three newcomers in each class will receive an engraved medal.

• **Manufacturers Solo Championship Award**

To the overall leading manufacturer across all solo races worked out on a World Championship points system.

• **Manufacturers Sidecar Championship Award**

To the overall leading manufacturer (chassis) across all Sidecar races worked out on a World Championship points system.

• **Club Team Award**

A Club affiliated to any FMN may nominate one team of three Competitors in each race. The Club Secretary must sign a declaration confirming that all drivers were registered members before the start of Practice. The Competitors will be required to sign a declaration stating that they represent one Club only.

Entry Details - Entries must be made on the official form available from the Race Office. The completed form must be lodged at the Race Office no later than 1700 hrs on the day preceding the race, along with an entry fee of £25 per team. No changes will be accepted after that time except that, in the case of a postponement of a race to another day, one or more riders may be substituted, no later than 1700 hrs on the day preceding the day to which the race is postponed.

A medal will be awarded for the team who complete the total distance of the race in the shortest aggregate time. A medal will also be awarded to each driver and passenger.

25. TT PRIVATEERS CUP CHAMPIONSHIP

The TT Privateer Championship is a new introduction to the TT Races. It allows solo teams and solo riders of independent status to compete with recognition at the highest level in the world's premier closed public roads motorcycle race.

Application for entry must be made to the promoters who will consider each application individually on its own merits using the following criteria:

1. Declaration by the team of no direct manufacturer assistance
2. The known ability of the rider
3. The motorcycle
4. The team operation, resources and structure
5. Other promotable elements e.g. media support

Any rider who has finished within the top 10 in any solo race at the previous years TT is ineligible to enter.

The promoter will be the final arbiter regarding rider eligibility and acceptance.

Points will be awarded to the first fifteen finishers in the Superbike, Superstock, Supersport and the Senior TT Races using a world championship points scoring system.

Awards will be made to the first three overall in the championship at the end of the event as follows –

1 st	£2,000
2 nd	£1,000
3 rd	£500

26. PRIZE PRESENTATIONS

Prize Presentations will take place at the following times and venues and all competitors are requested to attend -

1930hrs, Monday 7th June, Villa Marina, Douglas

Superbike TT Race
Sidecar TT Race 1
Supersport TT Race 1

1930hrs, Wednesday 9th June, Villa Marina, Douglas

Superstock TT Race
Sidecar TT Race 2
Supersport TT Race 2

2000hrs, Friday 11th June, TT Festival Entertainment Zone, Douglas Promenade

Senior TT Race
Special Awards
Solo TT Champion
Sidecar TT Champion

27. TRANSPONDERS AND AUTOMATIC TIMING

All qualifying sessions and races will be officially timed using a transponder based automatic timing system.

It is the responsibility of each competitor to provide and properly fit a fully charged transponder Type AMB TranX 260 or a directly compatible equivalent at his own expense. A separate transponder must be provided for each machine entered.

The identification number(s) of the transponder must be the same as the identification number(s) on the Entry Form for that machine and class. No additional Transponder/Lap Recorder device is permitted on the machine during practice or races.

Any application for a change of Transponder identification number must be made to the Clerk of the Course at least two hours before the start of qualifying session or race.

See also Appendix F.

28. ON BOARD CAMERAS AND GLOBAL POSITIONING SYSTEMS

The broadcast rights holder will nominate riders to carry cameras and / or global positioning systems on their machines. The installation of the camera, GPS and associated equipment is further subject to the approval of the Chief Technical Officer. No other riders or machines may carry on board cameras or GPS.

A machine carrying a starting number between 1 and 15 must carry an on-board camera if requested to do so by the broadcast rights holder. The camera will be fitted by the broadcast rights holder who will have the freedom to decide on the positioning of the camera and framing of the shot.

29. MOBILE PHONES

The carrying and use of a mobile phone in the Technical Inspection bay and the Pit Lane is forbidden unless the device is intrinsically safe.

30. VEHICLE RECOVERY SERVICE

A recovery service will operate throughout the practice and races. Any machines collected will be returned to the Technical Inspection Bay. The Organisers do not accept any responsibility for any damage to any machine.

31. STEWARDS OF THE MEETING

The first meeting of the Stewards will take place prior to the commencement of qualifying, after the Chief Steward has inspected the Course. The Stewards will then meet as directed by the Chief Steward.

Appeals to the Stewards must be made in writing and accompanied by the appropriate fee and should be handed to the Secretary of the Meeting.

32. ACCEPTANCE OF RECORDS

Entrants, riders and passengers must accept the official records of the organisers which may be published as the organisers thinks fit, and also agree not to publish, or allow to be published, on their behalf, any inaccurate, misleading or premature advertisement in connection with these races.

33. JURISDICTION

Each entry, if accepted, will form a contract between organisers and the entrant/rider which will be governed by and construed in all respects in accordance with Isle of Man law. Each of the parties irrevocably submits to the jurisdiction of the Isle of Man Courts in respect of any legal action or proceedings arising out of the contract or the participation of the entrant/rider in the meeting.

34. PUBLICITY

Competitors, wearing their leathers or Team uniform, must take part in any autograph session, Paddock walkabout and pre-race parade, should this be requested by the Promoter.

Each competitor, as requested, must make themselves available free of any charge or expenses to the Promoter during event promotional purposes.

All competitors, who qualify for an award shall attend the podium ceremony. Failure to attend the podium ceremony may result in a penalty being imposed by the organiser and/or promoter.

In signing the 2010 Isle of Man TT Entry Form each competitor and team agree that the promoter and the event sponsors may make use of his/her activities and successes in motorcycle sport for any advertising, publicity, public relations and merchandising purposes.

All riders may be required to carry an event and/or sponsors logo.

35. MERCHANDISING

The competitor and team will authorise the Promoter to use and reuse and licence the use of images and representations of the competitor and team motorcycles competing in the event (including the manufacturer's name and logo), and the name, images and representations of the competitor and team and team paraphernalia including (in so far as the same appears on the clothing worn by the competitor or on team paraphernalia or on the motorcycles participating in the event) the logo and decals of all sponsors of the competitor and/or team for the purpose of producing merchandise exploiting the reputation of the event.

The competitor and team acknowledge and agree that the Promoter and those authorised by it have the exclusive right to produce or authorise the production of interactive games of the event and games including individual elements of the event.

The competitor and team authorise the Promoter to use and licence others to use all event images and other material relating to the event in marketing and packaging material and commercial advertisements exploiting the event or merchandise of the event or any individual elements of the event.

The competitor and team shall assist the Promoter and those authorised by it with the promotion of the event and production and promotion of merchandise associated with the event.

36. MISCELLANEOUS

Riders, sponsors, manufacturers, teams, team personnel and officials may not either individually or with any such participants or through any representative or agent, procure, solicit or arrange for any supplies, gratuities, products, merchandise, equipment or any other thing of value to be provided from any source whatsoever bearing or depicting the official TT logo and/or any trademark and/or any copyright and/or image used or associated with the event without the prior written permission of the Promoter to do so.

All images, photographs, recordings or representations of the participation in the event or association with the event of manufacturers, competitors, entrants and teams may only be used for commercial purposes with the prior written consent of the Promoter (such consent not to be unreasonably withheld). No consent is required for normal media reporting of the event.

All the broadcast, recording, terrestrial, cable, satellite, digital, video and rights in all other media (including but not limited to WAP or similar mobile communications platforms and/or devices, Internet, Interactive and/or other competitor accessed sources) to Championship Events are the property of the Promoter.

Any recording, broadcast, rebroadcast or reproduction without express permission of the Promoter is strictly prohibited. Competitors, entrants teams, sponsors or manufacturers currently registered in the event may, subject to the prior written permission of the Promoter and subject to any conditions that they may impose at their absolute discretion, be granted rights to use broadcast material for their own specific promotional use within the UK without fee or charge except any that may be levied for technical and or research purposes. Rights requested by sponsors, advertisers, or any other commercial use must be made in writing to the Promoter and will be subject to Licence, which may include a fee or charge.

PRIZE MONEY

Superbike TT Race

Total Prize Fund – £68,575

Position	Lap 1	Lap 2	Lap 3	Lap 4	Lap 5	Lap 6	Total
1	£200	£300	£500	£1,000	£2,000	£16,000	£20,000
2	£150	£200	£300	£800	£1,500	£10,050	£13,000
3	£100	£150	£200	£600	£1,000	£6,950	£9,000
4	£75	£100	£150	£400	£725	£4,550	£6,000
5	£50	£75	£125	£300	£500	£2,950	£4,000
6	£25	£50	£100	£250	£300	£2,275	£3,000
7	£0	£0	£75	£175	£200	£1,550	£2,000
8	£0	£0	£50	£125	£175	£1,150	£1,500
9	£0	£0	£25	£100	£150	£1,050	£1,300
10	£0	£0	£0	£75	£125	£1,000	£1,200
11	£0	£0	£0	£50	£100	£950	£1,100
12	£0	£0	£0	£25	£75	£900	£1,000
13	£0	£0	£0	£0	£50	£850	£900
14	£0	£0	£0	£0	£25	£800	£825
15	£0	£0	£0	£0	£0	£750	£750
16	£0	£0	£0	£0	£0	£700	£700
17	£0	£0	£0	£0	£0	£650	£650
18	£0	£0	£0	£0	£0	£600	£600
19	£0	£0	£0	£0	£0	£550	£550
20	£0	£0	£0	£0	£0	£500	£500

Sidecar TT Race I

Total Prize Fund – £34,000

Position	Lap 1	Lap 2	Lap 3	Total
1	£250	£1,750	£7,000	£9,000
2	£150	£1,000	£3,850	£5,000
3	£100	£400	£2,500	£3,000
4	£75	£350	£2,075	£2,500
5	£50	£300	£1,650	£2,000
6	£50	£250	£1,400	£1,700
7	£0	£200	£1,300	£1,500
8	£0	£100	£1,200	£1,300
9	£0	£50	£1,050	£1,100
10	£0	£50	£950	£1,000
11	£0	£25	£925	£950
12	£0	£0	£750	£750
13	£0	£0	£700	£700
14	£0	£0	£650	£650
15	£0	£0	£600	£600
16	£0	£0	£550	£550
17	£0	£0	£500	£500
18	£0	£0	£450	£450
19	£0	£0	£400	£400
20	£0	£0	£350	£350

PRIZE MONEY

Supersport TT Race 1

Total Prize Fund – £35,000

<i>Position</i>	<i>Lap 1</i>	<i>Lap 2</i>	<i>Lap 3</i>	<i>Lap 4</i>	<i>Total</i>
1	£200	£300	£1,500	£8,000	£10,000
2	£150	£250	£900	£4,700	£6,000
3	£100	£200	£300	£3,400	£4,000
4	£75	£100	£250	£2,575	£3,000
5	£50	£75	£200	£1,675	£2,000
6	£25	£75	£150	£1,250	£1,500
7	£0	£50	£100	£1,050	£1,200
8	£0	£25	£75	£900	£1,000
9	£0	£0	£75	£825	£900
10	£0	£0	£75	£775	£850
11	£0	£0	£50	£750	£800
12	£0	£0	£50	£700	£750
13	£0	£0	£0	£550	£550
14	£0	£0	£0	£500	£500
15	£0	£0	£0	£450	£450
16	£0	£0	£0	£400	£400
17	£0	£0	£0	£350	£350
18	£0	£0	£0	£300	£300
19	£0	£0	£0	£250	£250
20	£0	£0	£0	£200	£200

Superstock TT Race

Total Prize Fund – £35,000

<i>Position</i>	<i>Lap 1</i>	<i>Lap 2</i>	<i>Lap 3</i>	<i>Lap 4</i>	<i>Total</i>
1	£200	£300	£1,500	£8,000	£10,000
2	£150	£250	£900	£4,700	£6,000
3	£100	£200	£300	£3,400	£4,000
4	£75	£100	£250	£2,575	£3,000
5	£50	£75	£200	£1,675	£2,000
6	£25	£75	£150	£1,250	£1,500
7	£0	£50	£100	£1,050	£1,200
8	£0	£25	£75	£900	£1,000
9	£0	£0	£75	£825	£900
10	£0	£0	£75	£775	£850
11	£0	£0	£50	£750	£800
12	£0	£0	£50	£700	£750
13	£0	£0	£0	£550	£550
14	£0	£0	£0	£500	£500
15	£0	£0	£0	£450	£450
16	£0	£0	£0	£400	£400
17	£0	£0	£0	£350	£350
18	£0	£0	£0	£300	£300
19	£0	£0	£0	£250	£250
20	£0	£0	£0	£200	£200

PRIZE MONEY

Supersport TT Race 2

Total Prize Fund – £35,000

<i>Position</i>	<i>Lap 1</i>	<i>Lap 2</i>	<i>Lap 3</i>	<i>Lap 4</i>	<i>Total</i>
1	£200	£300	£1,500	£8,000	£10,000
2	£150	£250	£900	£4,700	£6,000
3	£100	£200	£300	£3,400	£4,000
4	£75	£100	£250	£2,575	£3,000
5	£50	£75	£200	£1,675	£2,000
6	£25	£75	£150	£1,250	£1,500
7	£0	£50	£100	£1,050	£1,200
8	£0	£25	£75	£900	£1,000
9	£0	£0	£75	£825	£900
10	£0	£0	£75	£775	£850
11	£0	£0	£50	£750	£800
12	£0	£0	£50	£700	£750
13	£0	£0	£0	£550	£550
14	£0	£0	£0	£500	£500
15	£0	£0	£0	£450	£450
16	£0	£0	£0	£400	£400
17	£0	£0	£0	£350	£350
18	£0	£0	£0	£300	£300
19	£0	£0	£0	£250	£250
20	£0	£0	£0	£200	£200

Sidecar TT Race 2

Total Prize Fund – £34,000

<i>Position</i>	<i>Lap 1</i>	<i>Lap 2</i>	<i>Lap 3</i>	<i>Total</i>
1	£250	£1,750	£7,000	£9,000
2	£150	£1,000	£3,850	£5,000
3	£100	£400	£2,500	£3,000
4	£75	£350	£2,075	£2,500
5	£50	£300	£1,650	£2,000
6	£50	£250	£1,400	£1,700
7	£0	£200	£1,300	£1,500
8	£0	£100	£1,200	£1,300
9	£0	£50	£1,050	£1,100
10	£0	£50	£950	£1,000
11	£0	£25	£925	£950
12	£0	£0	£750	£750
13	£0	£0	£700	£700
14	£0	£0	£650	£650
15	£0	£0	£600	£600
16	£0	£0	£550	£550
17	£0	£0	£500	£500
18	£0	£0	£450	£450
19	£0	£0	£400	£400
20	£0	£0	£350	£350

PRIZE MONEY

Senior TT Race

Total Prize Fund – £68,575

Position	Lap 1	Lap 2	Lap 3	Lap 4	Lap 5	Lap 6	Total
1	£200	£300	£500	£1,000	£2,000	£16,000	£20,000
2	£150	£200	£300	£800	£1,500	£10,050	£13,000
3	£100	£150	£200	£600	£1,000	£6,950	£9,000
4	£75	£100	£150	£400	£725	£4,550	£6,000
5	£50	£75	£125	£300	£500	£2,950	£4,000
6	£25	£50	£100	£250	£300	£2,275	£3,000
7	£0	£0	£75	£175	£200	£1,550	£2,000
8	£0	£0	£50	£125	£175	£1,150	£1,500
9	£0	£0	£0	£100	£150	£1,050	£1,300
10	£0	£0	£0	£75	£125	£1,000	£1,200
11	£0	£0	£0	£50	£100	£950	£1,100
12	£0	£0	£0	£25	£75	£900	£1,000
13	£0	£0	£0	£0	£50	£850	£900
14	£0	£0	£0	£0	£25	£800	£825
15	£0	£0	£0	£0	£0	£750	£750
16	£0	£0	£0	£0	£0	£700	£700
17	£0	£0	£0	£0	£0	£650	£650
18	£0	£0	£0	£0	£0	£600	£600
19	£0	£0	£0	£0	£0	£550	£550
20	£0	£0	£0	£0	£0	£500	£500

Solo Champion

Position	Total
1	£10,000

Total Prize Fund – £10,000

Sidecar Champion

Position	Total
1	£3,000

Total Prize Fund – £3,000

Privateer Cup

Position	Total
1	£2,000
2	£1,000
3	£500

Total Prize Fund – £3,500

Martin Finnegan Award

Position	Total
1	£1,000

Total Prize Fund – £1,000

APPENDIX A

TT Superbike Specifications

Machines must comply with the 2010 FIM Regulations. These are obtainable on the following websites:-

FIM : <http://www.fim-live.com/en/sport/official-documents-ccr/codes-and-regulations/>

ACU: www.acu.org.uk

The following amendments apply to the TT Superbike:

Tyres

- This paragraph of the FIM Superbike Technical Specification does not apply to the TT. Tyres may be replaced from those fitted to the homologated motorcycles.
- Any suitable tyre may be used. There is no controlled tyre regulation for the TT
- Tyre warmers are allowed.
- Any tread pattern must be made exclusively by the manufacturer when producing the tyre. Additional tread grooves, cuts etc are allowed provided that they are made by a tyre manufacturer or by a person duly authorised by a tyre manufacturer. Such modified tyres must bear the distinguishing mark or stamp of the manufacturer. This stamp must be placed near to the manufacturer's mark.

Fuel Tank

- The FIM Regulation is modified by the addition of the following:- "The unleaded filler baffle may be removed from the fuel tank.

The following items MAY be removed:

- ADD to FIM Regulation: "Bank Angle Indicators ("hero bolts")"

APPENDIX B

Formula Two Sidecar TT Specifications

Formula II Sidecars must comply with the following requirements.

1. Engine Types

The only permitted engines for this class are:

- 501 - 600cc, 4 stroke, 4 cylinder, Production based
- Rotary engines are not permitted.
- Over-boring is not permitted.
- Induction systems:
- 501 - 600cc, 4 stroke Carburettor Engines: Any carburettor is permitted.
- 501 - 600cc four-stroke Fuel injection engines: Fuel injection systems are permitted using only the throttle-bodies as homologated for the engine concerned
- The injectors must be standard units as on the homologated engine.
- Variable length intake tract devices that function while the engine is operating are not permitted.
- Butterfly cannot be changed or modified. Where fitted a secondary butterfly or slide may be locked in the fully open position.
- Any fuel pump may be used.
- Homologated fuel pressure must remain unmodified.
- The fuel ignition ECU and Ignition Control Unit may be changed.

2. General Construction

- The Sidecar may be placed either side of the motorcycle. Hinged sidecars and steerable sidecar wheels are forbidden. Neither the rider nor passenger may be attached to the machine. Remote steering linkages and the use of articulated joints in the steering mechanism are not allowed. By definition an articulated joint is one allowing movement in more than one plane.
- The three road wheels may be disposed as to give two or three tracks.
- If three tracks are made then the centres of the tracks of the motorcycle shall not be more than 75mm apart.
- A passenger must be carried and must always be protected from the road wheels and both primary and final drives either by mudguard or some other means.

- The main frame (See Figure 1A) must consist of a minimum, of a steering head, a frame to accommodate the engine, and a main spar to the sidecar wheel, which will be made from good quality steel tube.
- The tubing used for the construction of the frame may be of a circular or non-circular section. If circular; the outside diameter shall not exceed 101.6mm. If non-circular; the maximum cross section shall not exceed 101.6mm. measured at right angles to any flat face.
- These three components must be permanently fixed by welding or brazing.
- The rear swinging arm outer pivot housings (See Figure 1B) may be detachable from the main frame, the pivot housings must be made from either steel or a suitable solid aluminium alloy billet. The finished article if made from aluminium alloy must be hard anodised. The use of castings for the outer pivot housings are forbidden.
- The sidecar wheel upright or flange plate (See Figure 1C) at the end of the main sidecar wheel spar may be detachable, the upright flange plate must be made from either steel or a suitable solid aluminium alloy billet. The finished article if made from aluminium alloy must be hard anodised, any supporting tie rods to the upright or flange plate must be made of steel. The use of castings for the sidecar wheel upright or flange plate are forbidden.
- The sidecar wheel stub axle housing (See Figure 1D) may be detachable from the sidecar wheel upright/flange plate; the housing must be made from either steel or a suitable solid aluminium alloy billet. The finished article if made from aluminium alloy must be hard anodised. The use of castings for the sidecar wheel stub axle housing are forbidden.
- Reinforcement of the steering head is allowed. The steering head may be fully boxed in to a maximum of 305mm, measured from any point between the top and the bottom of the steering head spindle centre line (See Figure 1 X.X). Should any lightening or inspection holes be added to the "Fully Boxed In" section, they will be deemed as still "Fully Boxed In" and not open.
- The front forks are to be either a leading / trailing fork, or links with the wheel equally supported on each side. The construction of the front forks and yokes must be made of good quality steel and must be either welded or brazed during construction. The lower loop must be made of good quality steel.
- Minimum suspension travel to be 20mm.
- The rear swinging arm must be made of good quality steel, single sided swinging arms are allowed, and must have minimum of 20mm of travel in a single plane. The rear swinging arm pivot spindle must be 90 degrees to the fore and aft centre line of the rear wheel. The swinging arm must either be welded or brazed during construction; the dimensions for the swinging arm are free. Wishbone type swinging arms fitted to monocoque chassis's are forbidden.
- The use of composite construction is forbidden with the exception of the sidecar platform, i.e. aluminium or carbon fibre skinned honeycomb.
- The use of titanium in the construction of the frame, front forks, handle bars, swinging arm and wheel spindles is forbidden.
- For wheel spindles, the use of light alloys is also forbidden.
- Under trays must be detachable.
- Monocoque construction is forbidden.

3 Engine Position

- The engine must be positioned in such a way that the centre line of the engine (by definition a position midway between centre lines of outermost cylinders) shall not exceed 160mm beyond the centre line of the rear wheel of the motorcycle.
- The engine must be positioned behind the steering head and in front of the driver.
- The drive must be transmitted to the road through the rear wheel of the motorcycle. An engine positioned behind the rider and in front of the rear wheel is forbidden.

4 Dimensions

- Weight (Minimum) 136.5kg. without fuel. The addition of ballast to reach this weight is forbidden.
- Width (Overall Maximum) 1575mm.
- Wheelbase (Maximum) 1651mm.
- Track 800mm minimum, 1105mm maximum. The distance is measured from the centre of the track left by the rear wheel to the centre of the track left by the sidecar wheel.
- Height (Overall Maximum) 800mm.
- Ground clearance. The ground clearance measured over the entire length and width of the vehicle race ready, fully loaded with rider, passenger and fuel must be not less than 65mm with the handlebars on in a straight position. No device is permitted to reduce the 65mm ground clearance during the course of the event.

Note: The imperial measurements are no longer used so the Metric figures have been rounded up to nearest mm the differences were 0.1mm and 0.2mm.

5 Streamlining and Bodywork

- The streamlining must be easily detachable for Technical Inspection. Aerofoils or spoilers are not permitted on streamlining.
- The forward extremity of the streamlining shall not be more than 400mm in front of the line taken from a vertical tangent to the front tyre.
- The extreme rear edge of the streamlining must not be more than 400mm to the rear of the line taken from a vertical tangent to the rear tyre.
- The provision of coachwork or streamlining is optional, but the vehicle must have accommodation for a passenger and the coachwork or streamlining shall not impede complete freedom of movement by the rider or passenger at all times.

- Whatever the position of the handlebars, there must be a space of at least 20mm between the streamlining and the ends of the handlebars or any other parts of the steering mechanism or front wheel.
- A solid and effective protection must be fitted between the rider and the engine, this protection must prevent direct contact between the riders body or clothing and escaping flames or leaking fuel or oil.
- The fairing must be mounted in such a way as to ensure the integrity of the whole installation in the event of failure of any individual mounting.

6 Passenger Platform

- Minimum dimensions 800mm by 300mm measured 150mm above the platform. The orientation is free.
- RIDER The rider in the normal riding position must be completely visible, with the exception of the arms, legs, and feet from above.
- PASSENGER The passenger must be able to lean out to either side of the sidecar; for this purpose the vehicle must be fitted with suitable hand-holds for the passenger to hold on to when leaning out. The hand-holds must be of the closed loop type, a single projection hand-hold is not permitted

7 Air Intakes

- Cooling air intakes must be so constructed that there is NO forward projection/protrusion to catch or foul in the event of accident.

8 Oil and Coolant Containment

- In the area directly below the engine, the oil containment tray must be constructed to hold, in case of an engine break down, at least half of the total oil and engine coolant capacity used in the engine (minimum 5 litres).
- The surrounding edges of the tray must be at least 30mm above the bottom of the tray.
- The frontal edge of the oil tray wall must be extended upwards to arrive just below (within 20mm) of the exhaust ports of the engine.
- Holes for the engine mounts (hangers) must be sealed.
- From a vertical view, the engine must be located completely inside the oil tray platform.
- The rear wheel must be protected from any possible oil spray. To make this protection, the engine and rear wheel compartment must be separated. This separation must be created by installing a solid divider (wall) running from the top of the inside of the bodywork to the bottom of the oil tray. This divider (wall) must overlap the rear edge of the oil tray down to the bottom.
- All machines must use this tray.
- All sidecars shall attach oil absorbent materials of no less a quality than 3M Product number T156 or CEP Sorbents product number CEP-EP100.
- This material shall be securely fixed to the following areas of the sidecar:
- The entire oil-tray, both the bottom and the inside walls of the same. The volume of material used in this area, according to the manufacturers specifications, shall absorb not less than 3 litres of oil.
- Any bodywork directly covering the engine.
- In the event that oil is absorbed by the material, it must be replaced before the next track session.
- The material must be attached in such a way that it should be easily replaced, yet must not become dislodged whilst on the track, and its effectiveness is not inhibited, i.e. if an adhesive is used it must not clog the material, causing it to lose its absorbent properties.
- All absorbent material shall be non-flammable by design.
- Oil-lines containing positive pressure, if replaced, must be of metal reinforced construction with swaged or threaded connectors.
- Oil coolers must not be mounted on or above the bodywork of the sidecar.
- The location of the oil tank and the oil cooler should be placed in a location where it is least likely to be damaged on an accident.

9 Airbox

- An airbox must be used with all four-stroke engines.
- The airbox intake sizes are restricted as follows:
- If 1 intake is used a maximum of 103mm Internal Diameter is permitted
- If 2 intakes are used a maximum of 73mm Internal Diameter per intake is permitted or equivalent area if none circular section(s) are used measured within 50mm of the point of entry into the airbox.
- The airbox must completely close around the induction bell-mouths.
- The carburettors or throttle-bodies may be entirely within the airbox.
- The engine must have a closed breather system.
- The engine breather must be connected and discharge in the airbox.
- The airbox must cover and collect fluids discharged from the bell-mouths.
- The airbox must be constructed in such a way as to prevent any oil discharged in the airbox from spilling on the track.
- This oil containment must hold a minimum of 1000 cc of oil.
- The airbox must be sealed to prevent spillage of oil or fuel.

10 Oil Catch Tanks

- Four-stroke. Motorcycles must have a closed breather system. The oil breather line must be connected and discharge into the airbox.

11 Wheels

- The minimum diameter of an inflated tyre must be 400mm. All wheels must be of metal construction, any modification to the rim or the spokes of the original cast composite wheel as supplied by the manufacturer is prohibited.

12 Steering

- Steering of the front wheel must be accomplished by non-adjustable handlebars securely fixed to the forks or yokes of the motorcycle. They must be secured to steering members turning the front wheel and its supports directly with no intermediate push or pull rods. Handlebars and all steering bearings must be located on the sprung portion of the front suspension.
- Any form of remote steering is forbidden.
- Handlebar width 450mm minimum.
- Steering lock angle each side of straight ahead position to be 20 degrees minimum, measured at the headstock.
- Whatever the position of the handlebars the front wheel must never touch the streamlining.
- Handlebar clamps must be carefully radiused and engineered so as to avoid fracture points in the bar.

13 Throttle Controls

- Throttle controls must be self-closing when not held by the hand.

14 Control Levers

- All handlebar levers (clutch, brake etc.) must be ball ended. The ball diameter must be at least 19mm permanently fixed and forming an integral part of the lever.

15 Brakes

- All three wheels must be braked. The brake system must consist of:
- One main system with at least two circuits operating separately, one of the circuits must operate on at least two of the three wheels.
- If one circuit fails the other must work efficiently.
- An emergency system operated by a handlebar lever with a simple circuit operating on either the front or rear wheel of the motorcycle.
- Only ferrous discs allowed.

16 Tyres

- For all meetings the use of slick tyres is permitted. The wheel rim shall be at least 254mm in diameter and 64mm in width. The diameter of the tyre must be at least 400mm and the width 100mm, maximum front tyre width 220mm.
- The surface of a slick tyre must contain two or more hollows at 180 degree intervals or less, indicating the limit of wear on the centre and shoulder areas of the tyre. When at least two of these indicator hollows become worn on different parts of the periphery, the tyre must no longer be used.

17 Mudguards and Wheel Protection

- The rear driving wheel must be covered down to the level of the sidecar platform on the nearest side to the sidecar wheel, and to the top of the rear wheel rim flange on the outside.
- The rear facing section of the rear seat must cover the rear driving wheel down to the level of the rear wheel spindle.
- The sidecar wheel must be enclosed from the sidecar platform and level with the sidecar platform on the outside and around the periphery. Provision for the checking of the sidecar wheel tyre pressure is allowed.

18 Exhaust Pipes

- The exhaust system must fulfil all the requirements concerning noise control. Exhaust fumes must be discharged in a manner so as to not raise dust, foul the tyres or brakes or inconvenience a passenger or any other driver. The furthest extremity of the exhaust pipe must not exceed a vertical line drawn at a tangent to the rear edge of the sidecar platform.
- On the side opposite a sidecar the exhaust pipes must not extend beyond the streamlining. On the other side the exhaust pipes must not extend beyond the width of the sidecar.
- Exhaust pipes must be fitted/positioned so that it is impossible for them to become entangled with another machine.

19 Fuel Tank

- Fuel tanks must be sufficiently independently protected from the ground. A non-return valve must be fitted to the petrol tank breather pipe, this pipe must discharge into a suitable catch tank, minimum capacity 500ml.
- The fuel filler cap must be fitted in such a way that it does not protrude from the fairing and cannot be torn off in an accident.

20 Battery

- The battery must be covered in such a way that neither the driver nor the passenger can come into contact with the battery or its contents.

21 Cut out Device

- An ignition cut-out must be fitted to operate when the driver leaves the machine. This cut-out system must interrupt the primary circuit and must be wired for both the supply and return current. The cut-out must be placed as near to the centre of the handlebar as possible and must be operated by a non-elastic string of adequate length and thickness and strapped to the driver's body. A spiral cable (similar to that of a telephone wire) of maximum 1m extended length is permitted.
- Any electric fuel feed pump must be wired in such a way as to cut out if the engine cut-out device is operated.

22 Red Warning Light

- Sidecars must be equipped for all the duration of the event with a functional rear-facing red anti-fog lamp, measuring a minimum of 30 sq.cm and producing a minimum of 1500 MCD continuous light. Pulsating lights are not permitted.
- The light must be installed at least 100mm off the ground, located in the area between the back wheel and the sidecar platform.
- The light must be mounted on a part of the suspended body, (not on any unsuspended parts) and ensure no obstruction from the fairing and/or the passenger

23 Traction Control

- Any electronic traction control system is forbidden. Wheel speed sensors are not permitted.

24 Rear View Mirror

- External rear view mirrors having suitable dimensions and mountings are optional.

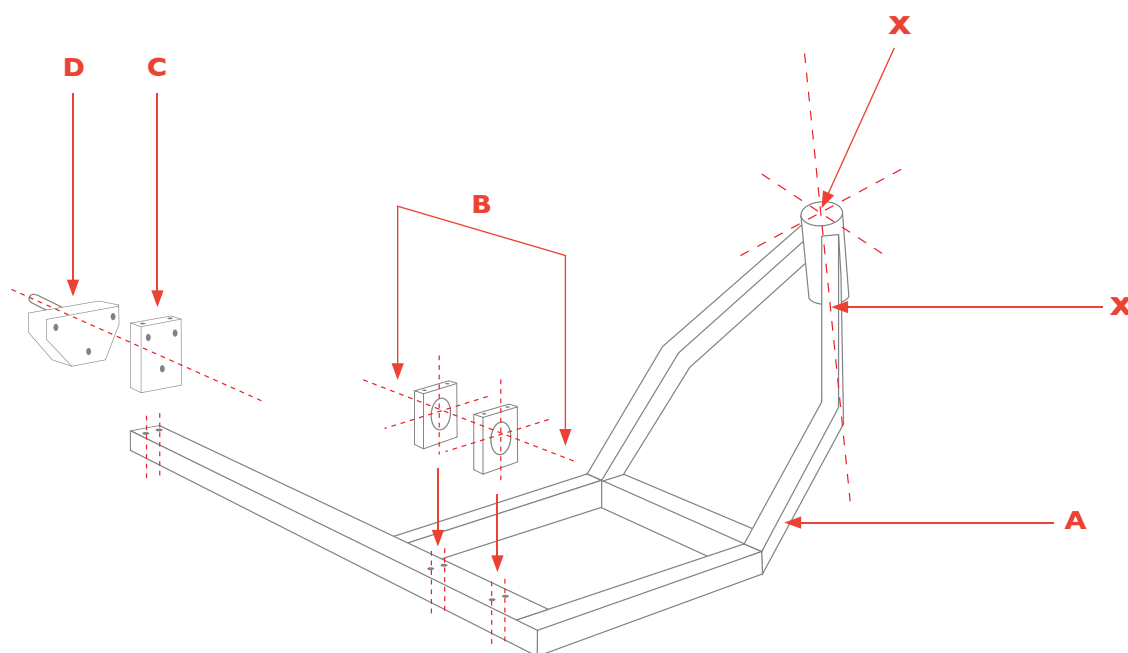

APPENDIX C

Note: This appendix is to be finalised on publication of 2010 FIM Regulations.

Supersport Junior TT Specifications

Machines must comply with the 2010 FIM Supersport Regulations. These are obtainable on the following websites:

FIM: <http://www.fim-live.com/en/sport/official-documents-ccr/codes-and-regulations/>
ACU: www.acu.org.uk

The following amendments apply to the Supersport Junior TT class

Tyres

- The FIM Regulations are replaced with the following TT Regulation:-
- "Any moulded treaded tyre may be used.
- The depth of tyre treads must be at least 2.5mm over the whole tyre tread (pattern) width, at pre-race control.
- Tyre warmers are allowed.
- The number of tyres to be used during the meeting is not restricted.

Windscreen

- The windscreen may be replaced by transparent material which may include a second screen with a maximum height above that of the original homologated screen of 150mm.
- As an alternative, a replacement screen, including a bubble of maximum height of 150mm, may replace the original homologated screen.

Fuel Tank

- The FIM Regulation is modified by the addition of the following :-
- "The unleaded filler baffle may be removed from the fuel tank. It is permitted to modify the standard manufacturer's tank provided the silhouette of the tank remains as homologated."

The following items MAY be removed

- ADD to FIM Regulation: "Bank Angle Indicators ("hero bolts")"
-

APPENDIX D

Note: This appendix is to be finalised on publication of 2010 FIM Regulations.

TT Superstock Regulations

Machines must comply with the 2010 FIM Superstock Regulations. These are obtainable on the following websites:

FIM: <http://www.fim-live.com/en/sport/official-documents-ccr/codes-and-regulations/>

ACU: www.acu.org.uk

The following amendments apply to the TT Superstock

Tyres

- The FIM Regulations are replaced with the following TT Regulation:-
- Any moulded treaded tyre may be used.
- The depth of tyre treads must be at least 2.5mm over the whole tyre tread (pattern) width, at pre-race control.
- Tyre warmers are allowed.
- The number of tyres to be used during the meeting is not restricted".

Windscreen

- The windscreen may be replaced by transparent material which may include a second screen with a maximum height above that of the original homologated screen of 150mm.
- As an alternative, a replacement screen, including a bubble of maximum height of 150mm, may replace the original homologated screen.

Fuel Tank

- The FIM Regulation is modified by the addition of the following :-
- "The unleaded filler baffle may be removed from the fuel tank.
- It is permitted to modify the standard manufacturer's tank provided the silhouette of the tank remains as homologated."

The following items MAY be removed

- ADD to FIM Regulation: "Bank Angle Indicators ("hero bolts")"

APPENDIX E

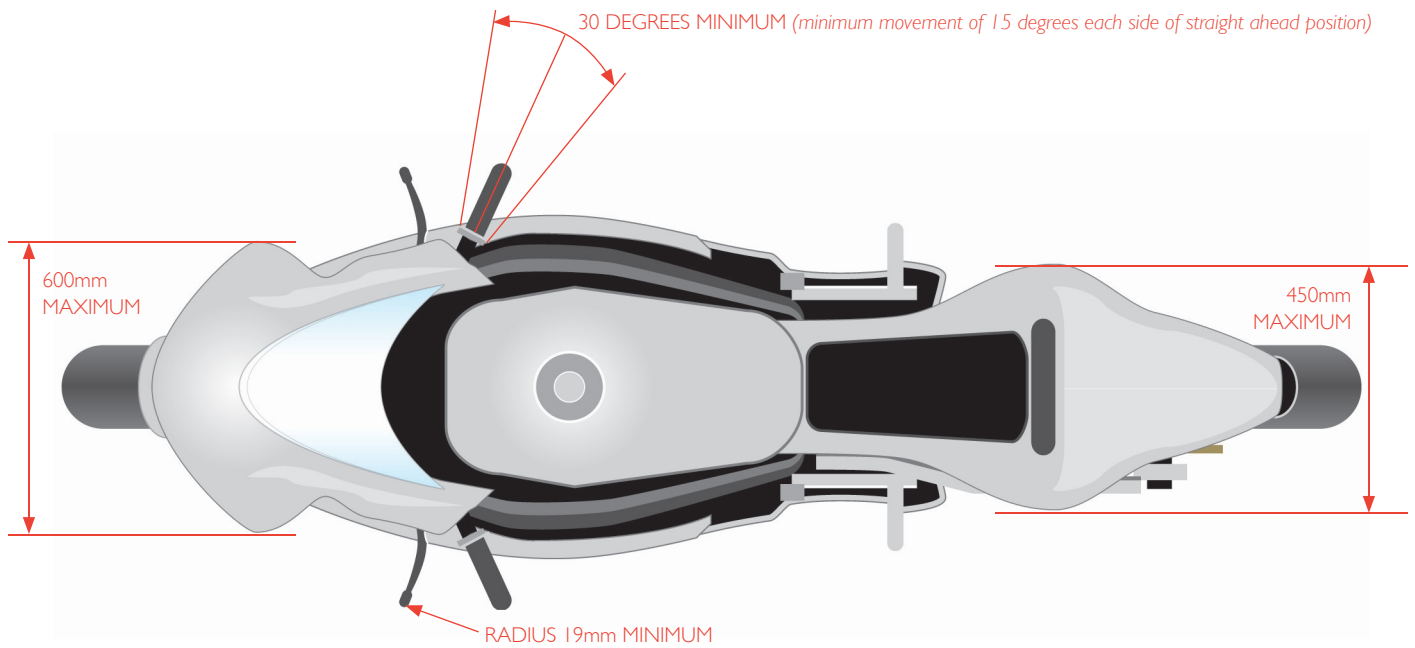
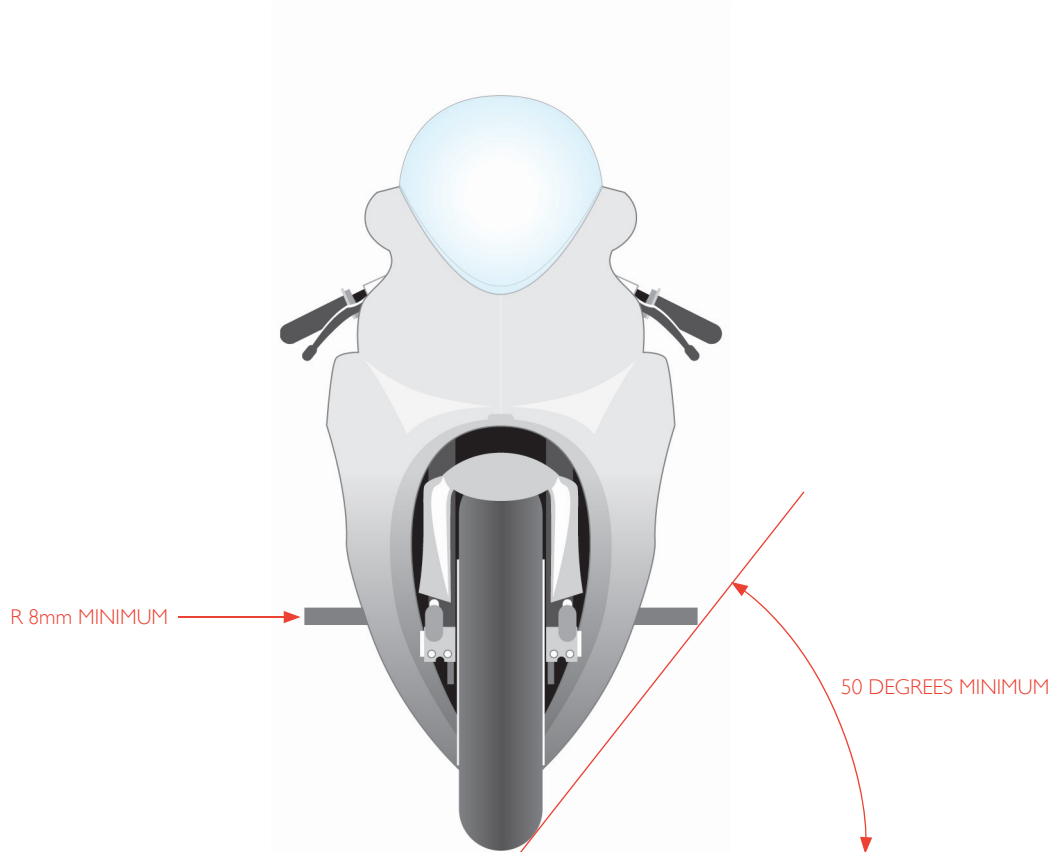

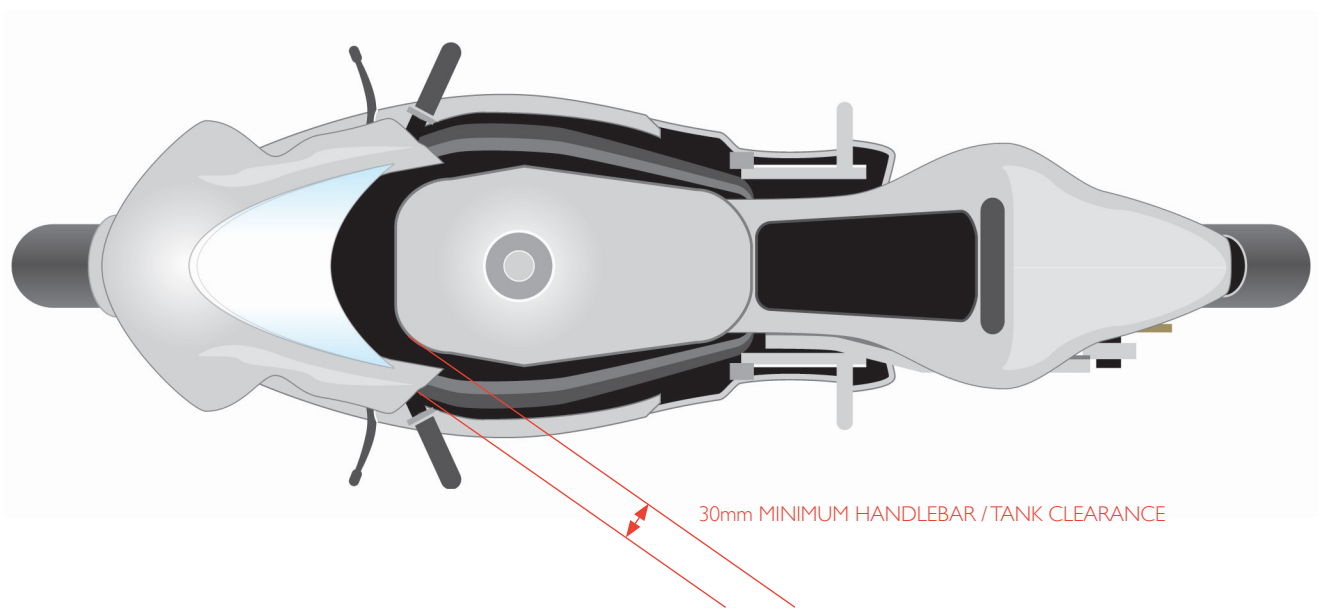
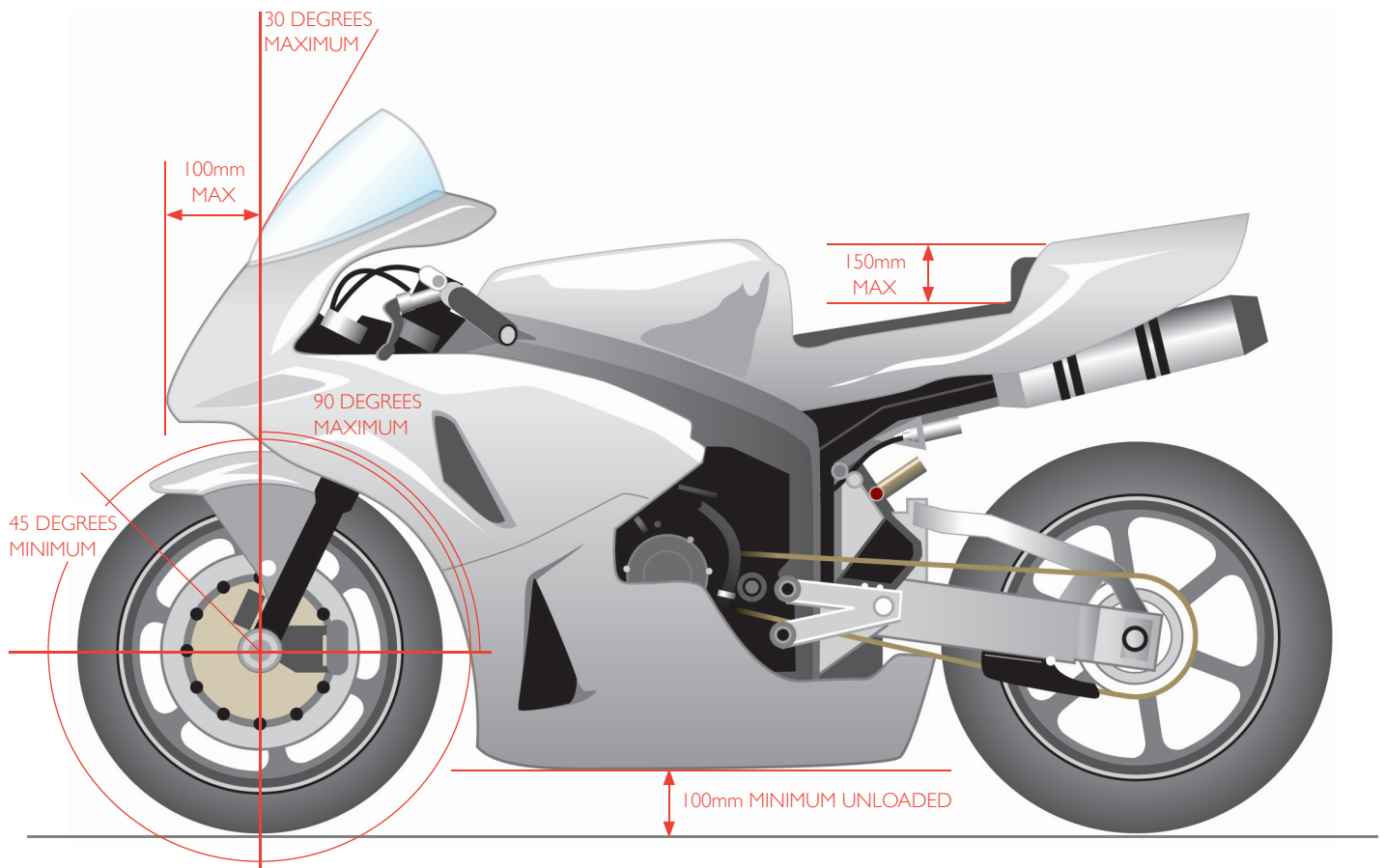

APPENDIX F

Transponders

- An AMBTranX 260 or compatible transponder must be used.
- Ensure that the transponder holder is fitted securely, preferably using bolts and Nylock nuts. (if tie-wraps are used at least two sufficiently strong tie-wraps are needed to secure the holder).
- The transponder must be mounted VERTICALLY and NOT horizontally.
- The securing pin must be at the top.
- Fit the transponder holder in a safe and secure position.
- Mount the transponder so that it is preferably no more than 2 ft (60 cm) from the ground.
- Mount the transponder so that it is away from heat generating bodies such as the exhaust.
- Mount the transponder so that it has as clear a view of the ground as possible. Note - The transponder signal will not pass through metal or carbon fibre based plastics.
- Push the 'R' clip right through as far as possible in order to prevent it being accidentally pushed out.
- The transponder must be fitted whenever your machine is taken into the assembly area and whenever it is on the course, including timed and untimed practice sessions.
- The transponder must be charged and 'flashing' green and fitted to the machine when presented for Technical Inspection.
- Disregarding any of the above guidelines may result in your time(s) not being recorded.
- No time will be recorded at all if the transponder is not fitted or has not been charged.
- If attached to the fork leg the transponder must not interfere with the steering lock.
- The transponder must not be fitted between the top and bottom yokes on the fork legs.

PREFERRED POSITIONS:

